

TA8159FN

1.5V STEREO HEADPHONE AMPLIFIER

The TA8159FN is developed for play-back stereo headphone equipments (1.5V use). It is built in dual auto-reverse pre amplifiers, dual OCL power amplifiers, and a ripple filter.

FEATURES

Power amp. stage

- OCL (Output Condenser-Less)
- Low noise : $V_{no} = 48\mu V_{rms}$ (Typ.)
- Output Power : $P_o = 6mW$ (Typ.)
(at $V_{CC} = 1.5V$, $f = 1kHz$, THD = 10%)
- Excellent ripple rejection ratio : RR = 54dB (Typ.)
- Voltage Gain : $G_V = 28dB$ (Typ.)
- Built-in power amplifier mute.

Pre-amp. stage

- Auto-reverse with F/R control switch
- Low noise : $V_{ni} = 1.7\mu V_{rms}$ (Typ.)
- Input coupling condenser-less
- Built-in input capacitor for reducing buzz noise
- Built-in pre-amplifier mute

Total

- Built-in ripple filter
- Built-in power switch
- Operating supply voltage range : $V_{CC(opr)} = 0.9V \sim 2.2V$ ($T_a = 25^\circ C$)

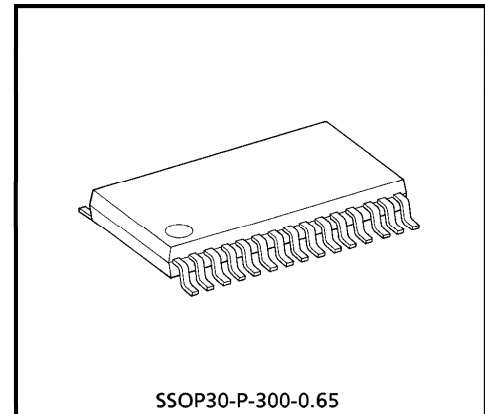

SSOP30-P-300-0.65
Weight : 0.17g (Typ.)

961001EBA2

- TOSHIBA is continually working to improve the quality and the reliability of its products. Nevertheless, semiconductor devices in general can malfunction or fail due to their inherent electrical sensitivity and vulnerability to physical stress. It is the responsibility of the buyer, when utilizing TOSHIBA products, to observe standards of safety, and to avoid situations in which a malfunction or failure of a TOSHIBA product could cause loss of human life, bodily injury or damage to property. In developing your designs, please ensure that TOSHIBA products are used within specified operating ranges as set forth in the most recent products specifications. Also, please keep in mind the precautions and conditions set forth in the TOSHIBA Semiconductor Reliability Handbook.
- The products described in this document are subject to foreign exchange and foreign trade control laws.
- The information contained herein is presented only as a guide for the applications of our products. No responsibility is assumed by TOSHIBA CORPORATION for any infringements of intellectual property or other rights of the third parties which may result from its use. No license is granted by implication or otherwise under any intellectual property or other rights of TOSHIBA CORPORATION or others.
- The information contained herein is subject to change without notice.

BLOCK DIAGRAM

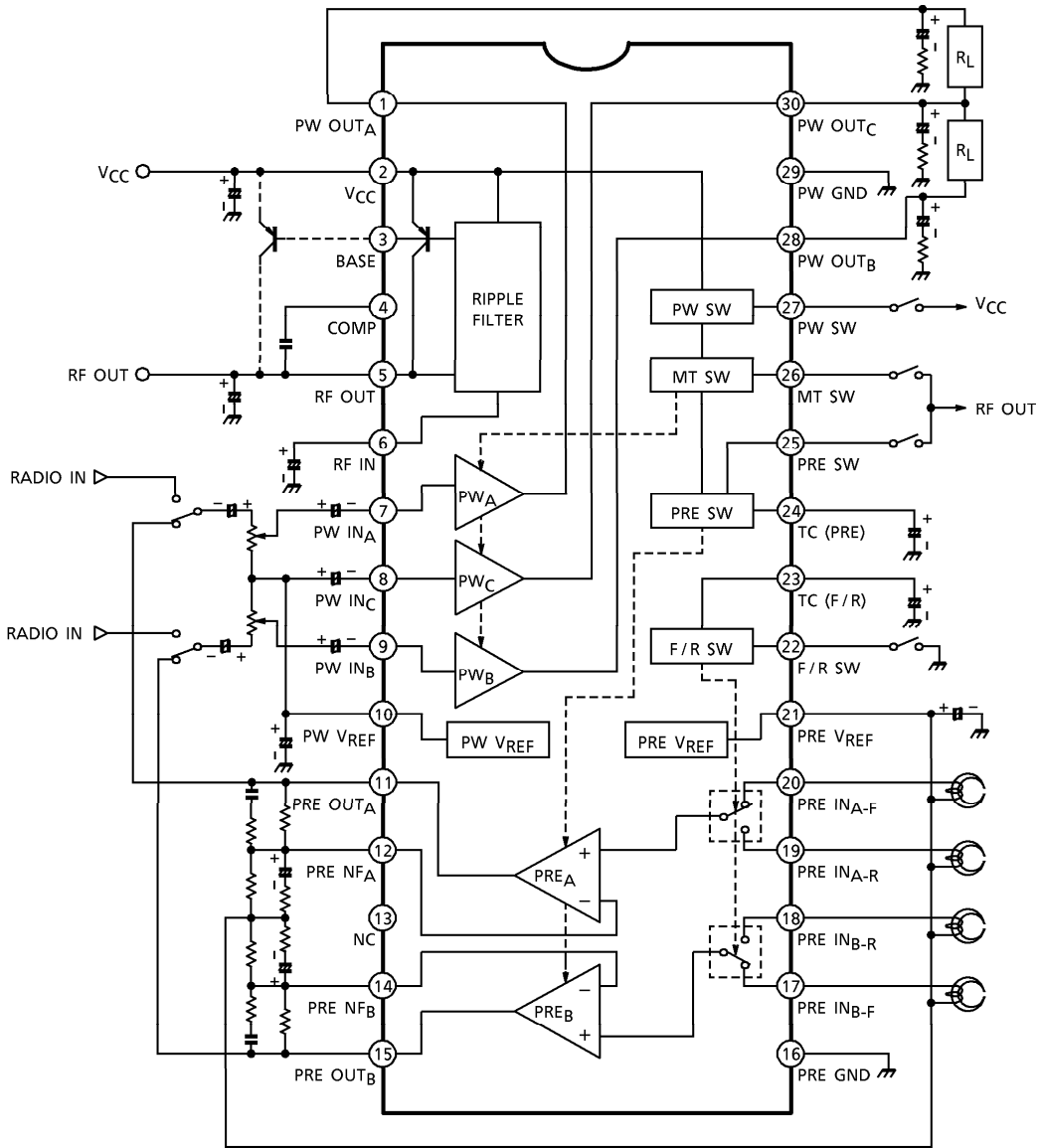

TERMINAL EXPLANATION

Terminal voltage : Typical terminal voltage at no signal with test circuit. ($V_{CC} = 1.2V$, $T_a = 25^\circ C$)

TERMINAL		FUNCTION	INTERNAL CIRCUIT	TERMINAL VOLTAGE (V)	
No.	NAME				
1	PW OUT _A	Output of power amplifier.		0.6	
28	PW OUT _B			0.6	
30	PW OUT _C	Output of common power amplifier.		0.6	
7	PW IN _A	Input of power amplifier.		0.75	
9	PW IN _B			0.75	
8	PW IN _C	Input of common power amplifier.		0.75	
2	V _{CC}	—			1.2
3	BASE	Base bias of an external PNP transistor for ripple filter.			0.5
4	COMP	Phase compensation of ripple filter circuit.			0.5
5	RF OUT	Ripple filter output. Ripple filter circuit supplies VREF circuit, Pre-amplifier circuit, and F/R switch circuit with power source.			1.13
6	RF IN	Ripple filter terminal.	1.13		
10	PW VREF	Reference voltage of power amplifier.		0.75	

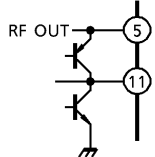
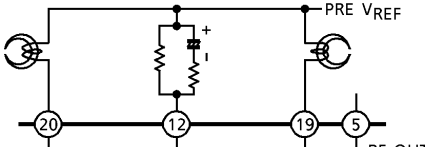
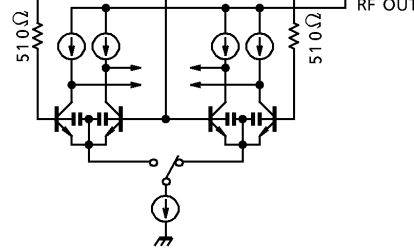
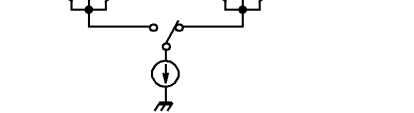
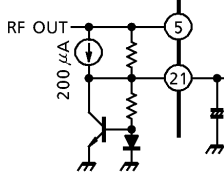
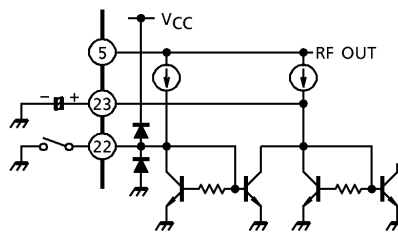
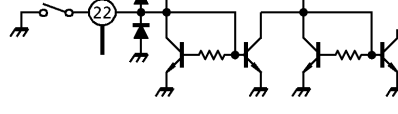
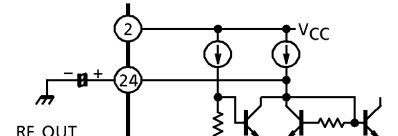
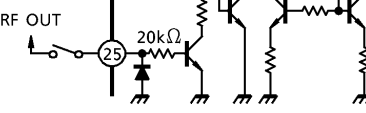
TERMINAL		FUNCTION	INTERNAL CIRCUIT	TERMINAL VOLTAGE (V)
No.	NAME			
11	PRE OUT _A	Output of pre-amplifier.		0.5
15	PRE OUT _B			
12	PRE NF _A	NF of pre-amplifier.		0.75
14	PRE NF _B			
17	PRE IN _{B-F}	Forward input of pre-amplifier. (at F/R SW : open)		0.75
20	PRE IN _{A-F}			
18	PRE IN _{B-R}	Reverse input of pre-amplifier. (at F/R SW : GND)		0.75
19	PRE IN _{A-R}			
13	NC	—	—	—
16	PRE GND	—	—	0
21	PRE V _{REF}	Reference voltage of pre-amplifier.		0.75
22	F/R SW	Forward / Reverse mode switch. (OPEN : Forward mode) (GND : Reverse mode)		—
23	TC (F/R)	Smoothing terminal. In order to reduce a pop noise at F/R switching.		0.7
24	TC (PRE)	Smoothing terminal. In order to reduce a pop noise at Pre-amplifier ON / OFF switching.		0.7
25	PRE SW	Pre-amplifier ON / OFF switch. (RF OUT : ON) (GND / OPEN : OFF)		—

TERMINAL		FUNCTION	INTERNAL CIRCUIT	TERMINAL VOLTAGE (V)
No.	NAME			
26	MT SW	Muting switch for power amplifier. (RF OUT : MUTE OFF) (GND / OPEN : MUTE ON)		—
27	PW SW	Power ON / OFF switch. (VCC : ON) (GND / OPEN : OFF)		—
29	PW GND	—		0

MAXIMUM RATINGS (Ta = 25°C)

CHARACTERISTIC	SYMBOL	RATING	UNIT
Supply Voltage	V _{CC}	3	V
Output Current	Power	I _o (peak)	60
	Ripple Filter	I _{RF}	5
Power Dissipation (Note)	P _D	550	mW
Operating Temperature	T _{opr}	-25~75	°C
Storage Temperature	T _{stg}	-55~150	°C

(Note) : Derated above Ta = 25°C in the proportion of 4.4mW/°C.

ELECTRICAL CHARACTERISTICS

Unless otherwise specified : V_{CC} = 1.2V, f = 1kHz, Ta = 25°C, SW₁ : a, SW₂ : a, SW₃ : a, SW₇ : on
 Power-amplifier stage : R_g = 600Ω, R_L = 16Ω, SW₃ : b, SW₆ : a
 Pre-amplifier stage : R_g = 2.2kΩ, R_L = 10kΩ, SW₂ : b, SW₅ : a

CHARACTERISTIC	SYMBOL	TEST CIR-CUIT	TEST CONDITION	MIN.	TYP.	MAX.	UNIT
Quiescent Current	I _{CCQ1}	1	POWER OFF, SW ₁ : b, SW ₂ : b	—	0.1	5	μA
	I _{CCQ2}		POWER Amp. OFF, SW ₂ : b	—	2.8	4.5	mA
	I _{CCQ3}		V _{in} = 0	—	13	16	mA
Power-amplifier Stage	Voltage Gain	GV	V _o = -22dBV	26	28	30	dB
	Channel Balance			—	0	1.5	
	Output Power	P _o	V _{CC} = 1.5V, V _{in} (A) = V _{in} (B) THD = 10%	5	6	—	mW
	Total Harmonic Distortion		V _{CC} = 1V, P _o (A) = P _o (B) = 1mW	—	0.4	1.5	%
	Output Noise Voltage		V _{no}	BPF : 20Hz~20kHz, SW ₆ : b	—	48	70

CHARACTERISTIC		SYMBOL	TEST CIR-CUIT	TEST CONDITION	MIN.	TYP.	MAX.	UNIT
Power-amplifier Stage	Ripple Rejection Ratio	RR ₁	2	V _{CC} = 1V, f _r = 100Hz, V _r = -32dBV I _{RF} = 0, SW ₆ : b, SW ₇ : open	45	54	—	dB
	Cross Talk (CH-A / CH-B)	CT ₁		V _O = -22dBV	30	38	—	
	Power Muting Attenuation	ATT ₁		V _O = -22dBV, SW ₂ : a→b	70	83	—	
Ripple Filter Stage	Output Voltage	V _{RF}	2	V _{CC} = 1V, I _{RF} = 0	0.88	0.92	—	V
	Ripple Rejection Ratio	RR ₂		V _{CC} = 1V, f _r = 100Hz, V _r = -32dBV I _{RF} = 30mA, SW ₇ : open	38	45	—	dB
Pre-amplifier Stage	Open Loop Voltage Gain	G _{VO}	2	V _O = -22dBV, SW ₅ : b	63	70	—	dB
	Closed Loop Voltage Gain	G _{VC}		V _O = -22dBV	—	34	—	
	Maximum Output Voltage	V _{om}		THD = 1%	160	290	—	mV _{rms}
	Total Harmonic Distortion	THD ₂		V _{CC} = 1V, V _O = 100mV _{rms}	—	0.06	0.3	%
	Equivalent Input Noise Voltage	V _{ni}		BPF : 20Hz~20kHz, SW ₈ : open NAB (f = 1kHz, G _V = 34dB)	—	1.7	2.7	μV _{rms}
	Cross Talk (CH-A / CH-B)	CT ₂		V _O = -22dBV	—	61	—	dB
	Cross Talk (Forward / Reverse)	CT ₃			—	61	—	
	Pre Muting Attenuation	ATT ₂			V _O = -22dBV, SW ₃ : a→b	—	75	
Power ON Current	I ₂₇	1	V _{CC} = 0.9V	V ₁₀ ≥ 0.5V, SW ₁ : c	5	—	—	μA
Power OFF Voltage	V ₂₇			V ₁₀ ≤ 0.3V, SW ₁ : d	0	—	0.3	V
Power Amp. Mute OFF Current	I ₂₆			V ₃₀ ≥ 0.4V, SW ₂ : c	5	—	—	μA
Power Amp. Mute ON Voltage	V ₂₆			V ₃₀ ≤ 0.3V, SW ₂ : d	0	—	0.3	V
Pre. Amp. ON Current	I ₂₅			V ₂₄ ≥ 0.5V, SW ₃ : c	5	—	—	μA
Pre. Amp. OFF Voltage	V ₂₅			V ₂₄ ≤ 0.3V, SW ₃ : d	0	—	0.3	V
Reverse Mode Voltage	V ₂₂			V ₂₃ ≥ 0.5V, SW ₄ : c	0	—	0.3	V

TEST CIRCUIT 1

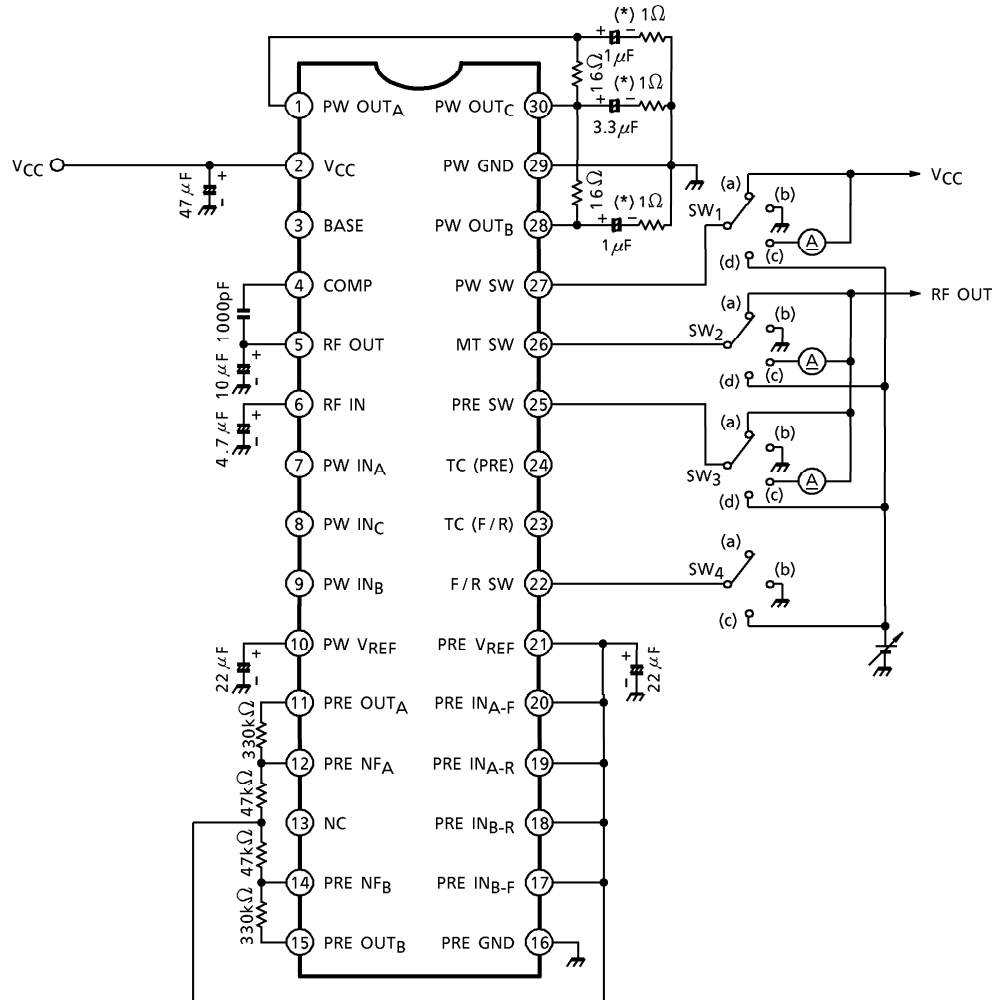

(*) Tantal Condenser

TEST CIRCUIT 2

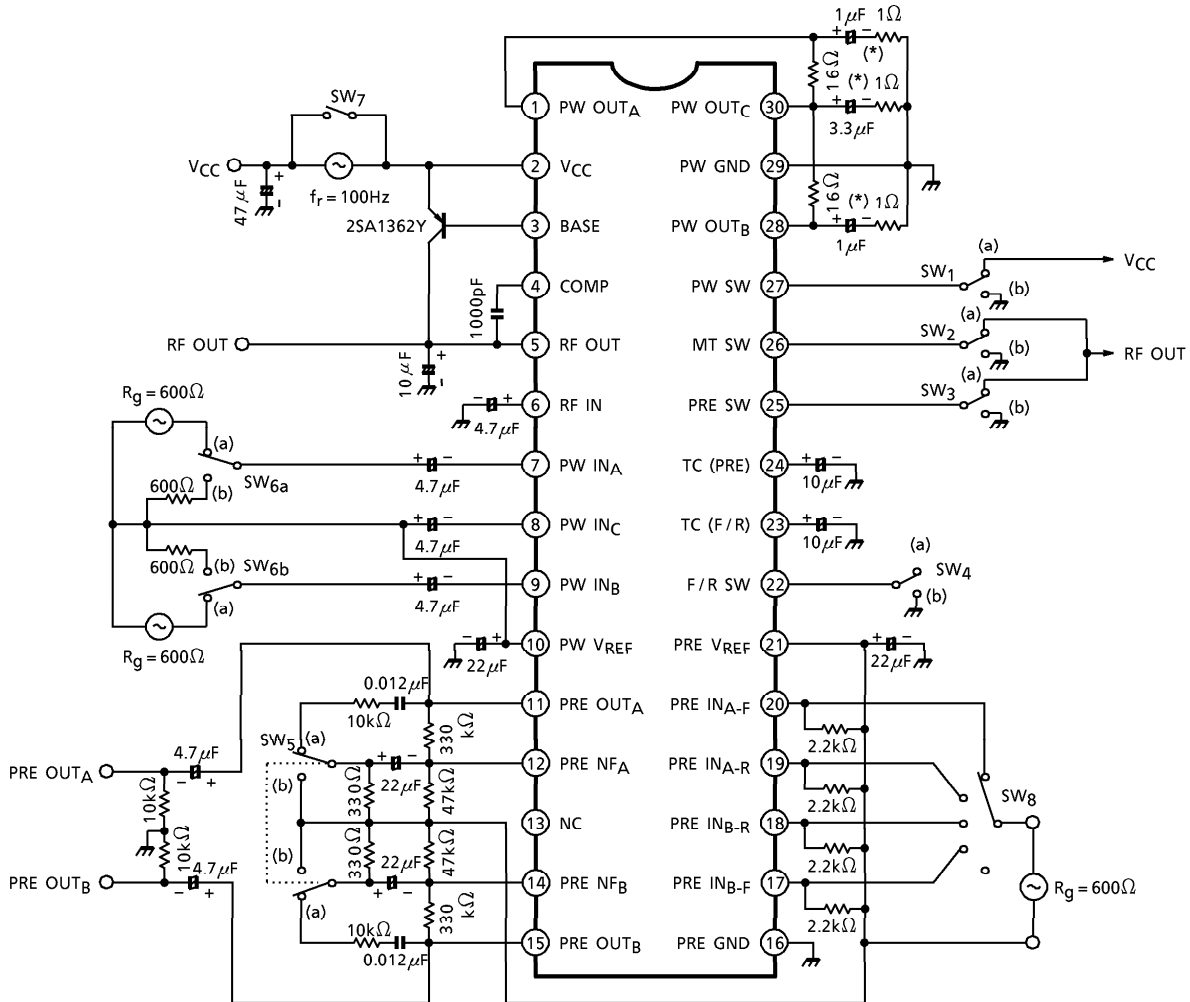

(*) Tantal Condenser

CHARACTERISTIC CURVES Unless otherwise specified : $V_{CC} = 1.2V$, $T_a = 25^\circ C$, $f = 1kHz$
 Pre-Amplifier Stage : $R_g = 2.2k\Omega$, $R_L = 10k\Omega$
 Power Amplifier Stage : $R_g = 600\Omega$, $R_L = 16\Omega$

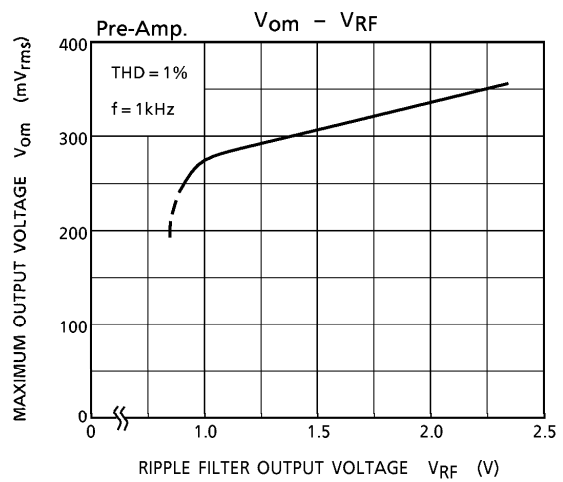
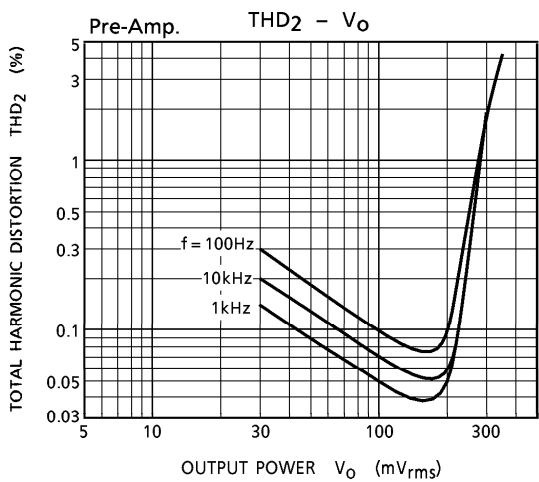
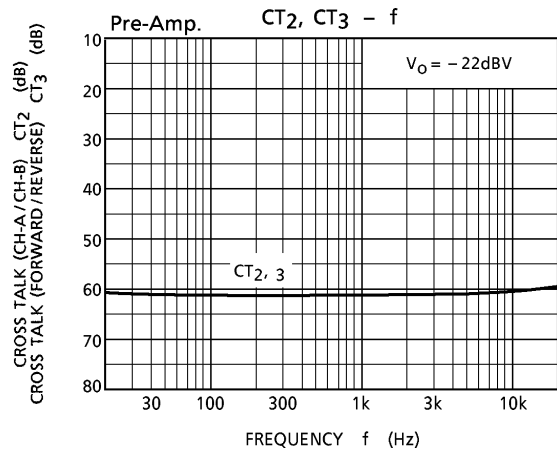
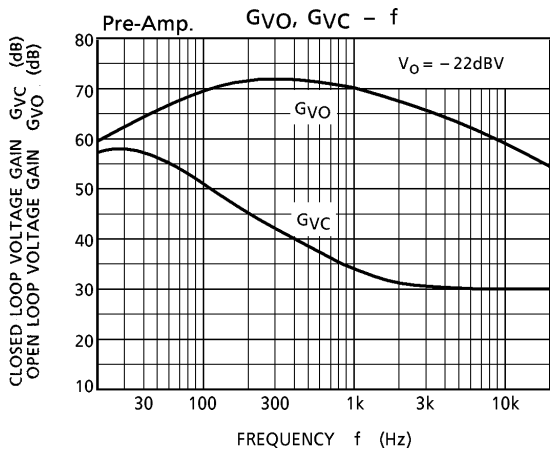
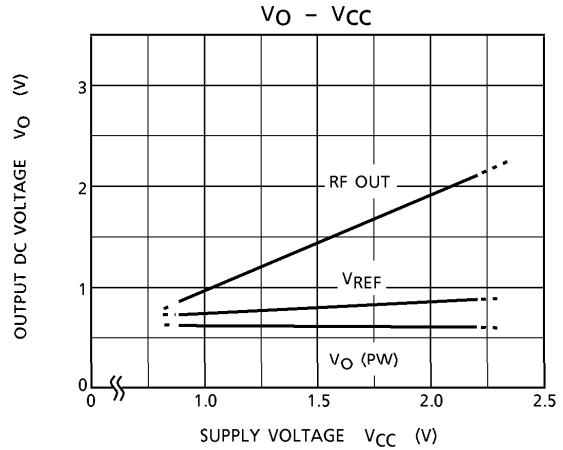
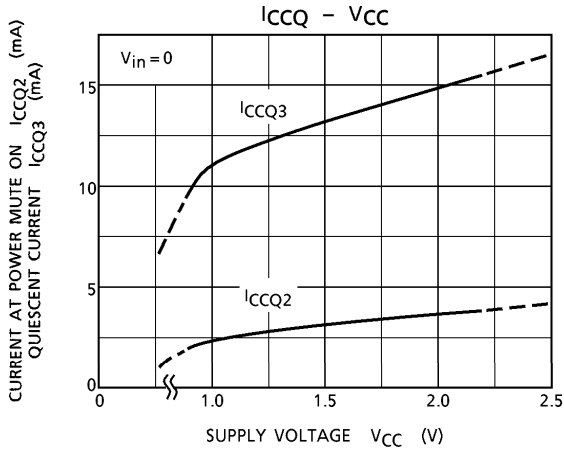

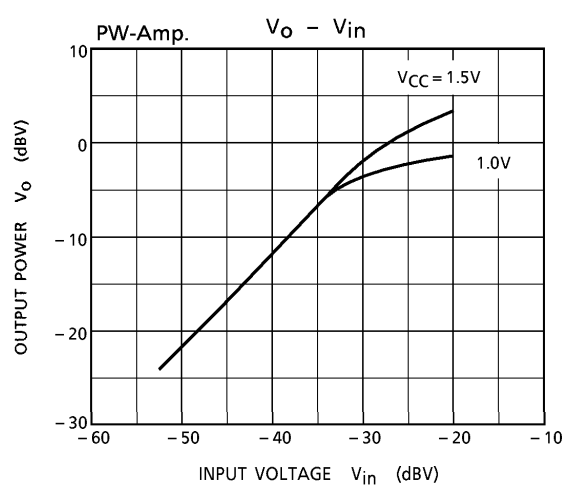
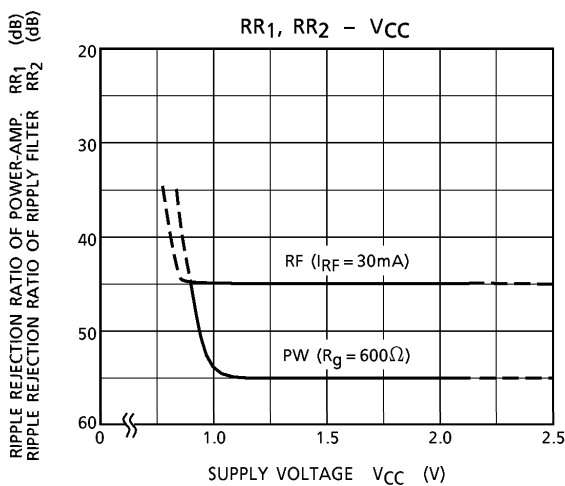
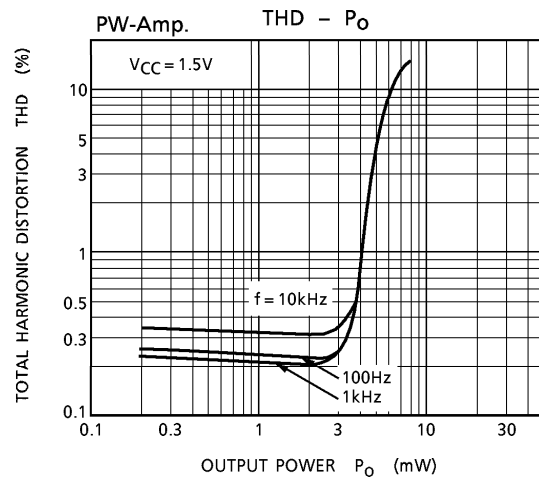
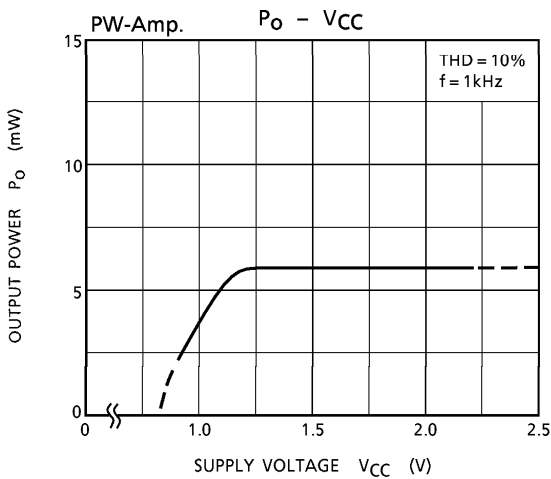
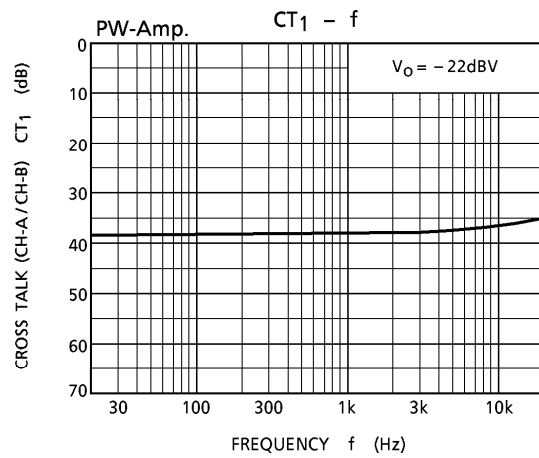
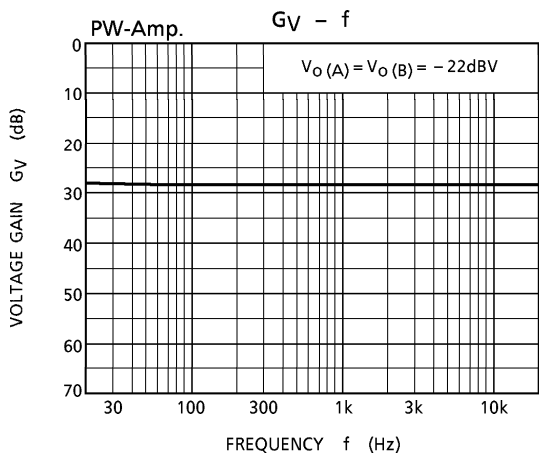

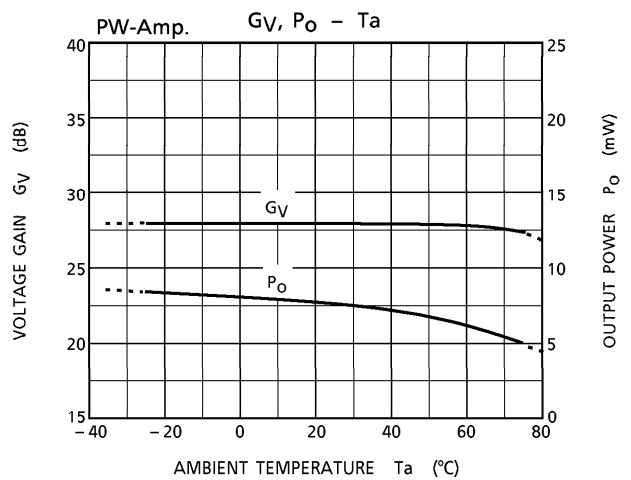
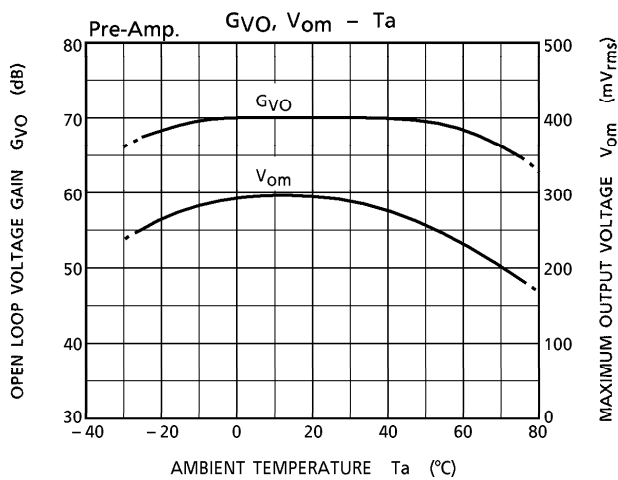
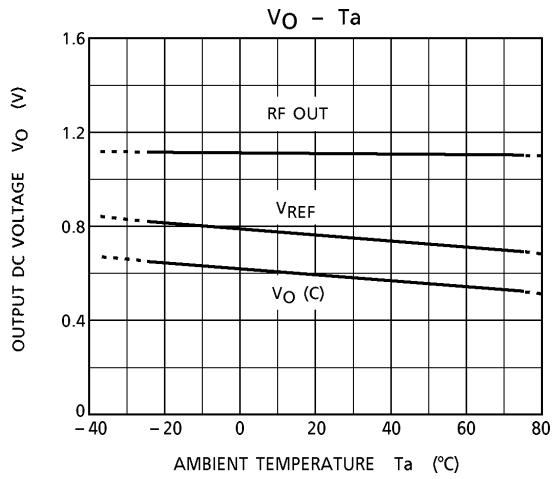
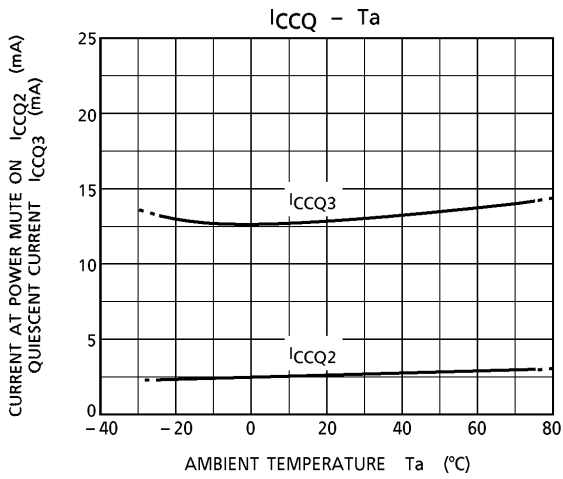
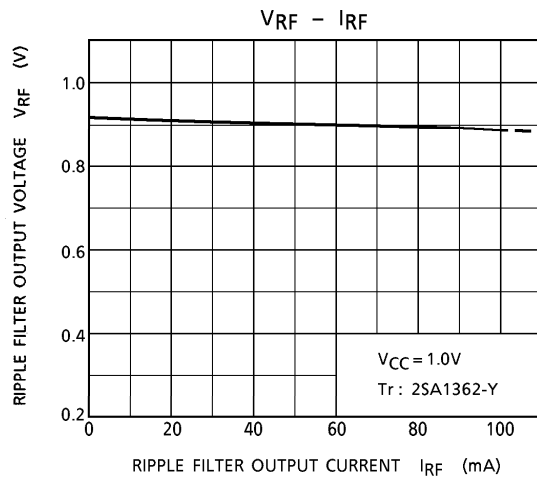
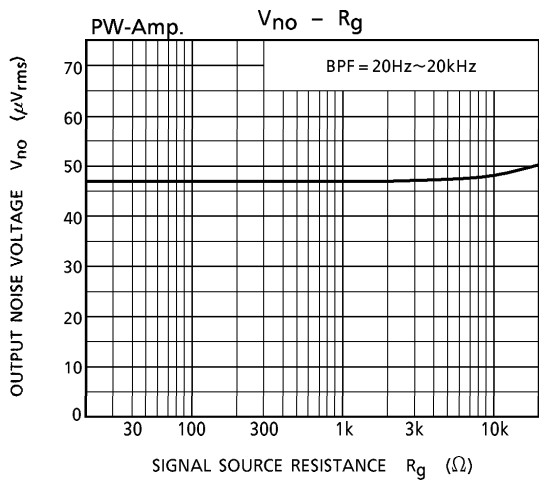

OUTLINE DRAWING
SSOP30-P-300-0.65

Unit : mm

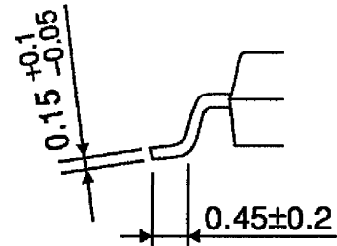
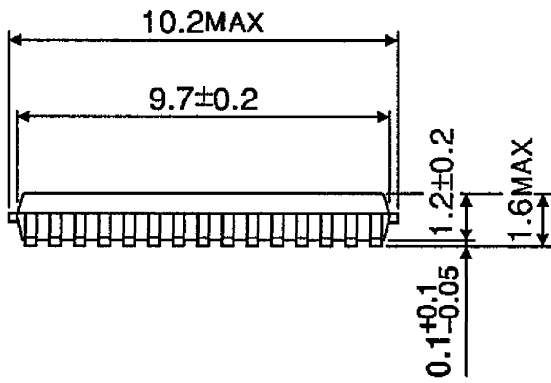
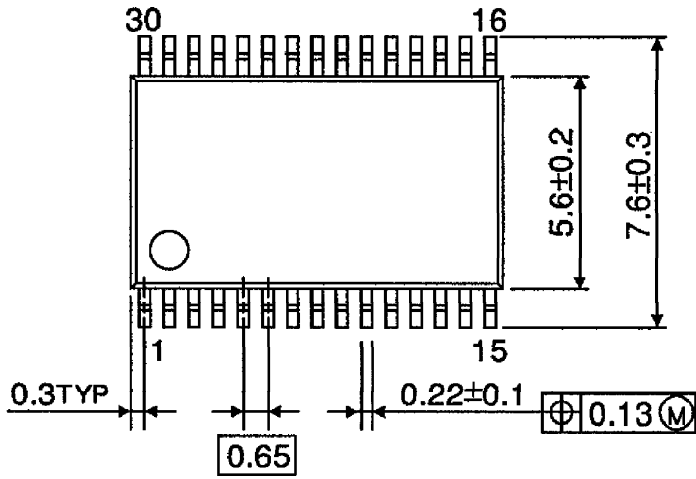

Weight : 0.17g (Typ.)