

Advance Information
1M x 4 CMOS Dynamic RAM

Write Per Bit Mode

The MCM54410A is a 0.7 μ CMOS high-speed, dynamic random access memory. It is organized as 1,048,576 four-bit words and fabricated with CMOS silicon-gate process technology. Advanced circuit design and fine line processing provide high performance, improved reliability, and low cost.

The MCM54410A requires only 10 address lines; row and column address inputs are multiplexed. The device is packaged in a standard 300-mil J-lead small outline package, and a 100-mil zig-zag in-line package (ZIP).

- Three-State Data Output
- Write Per Bit Mode
- Fast Page Capability
- Test Mode
- TTL-Compatible Inputs and Outputs
- RAS Only Refresh
- CAS Before RAS Refresh
- Hidden Refresh
- 1024 Cycle Refresh: MCM54410A = 16 ms
- Fast Access Time (t_{RAC}):
 - MCM54410A-60 = 60 ns (Max)
 - MCM54410A-70 = 70 ns (Max)
 - MCM54410A-80 = 80 ns (Max)
- Low Active Power Dissipation:
 - MCM54410A-60 = 660 mW (Max)
 - MCM54410A-70 = 550 mW (Max)
 - MCM54410A-80 = 468 mW (Max)
- Low Standby Power Dissipation:
 - MCM54410A = 11 mW (Max, TTL Levels)
 - MCM54410A = 5.5 mW (Max, CMOS Levels)

MCM54410A

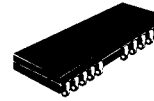

N PACKAGE
300-MIL SOJ
CASE 822

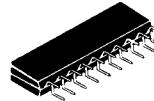

Z PACKAGE
PLASTIC
ZIG-ZAG IN-LINE
CASE 836

PIN ASSIGNMENT

100-MIL ZIP

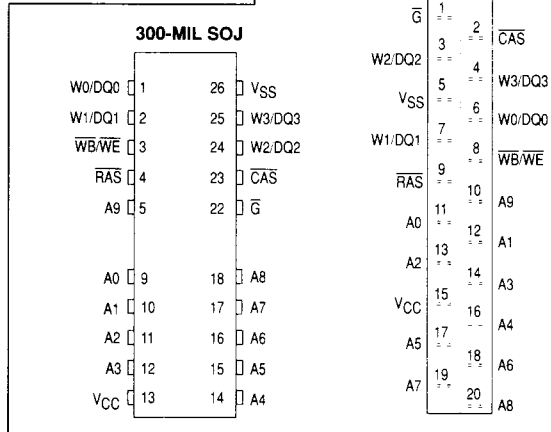

PIN NAMES

A0-A9	Address Input
W0/DQ0-W3/DQ3	Write Select/Data Input Output
Q	Data Output
W	Read/Write Enable
RAS	Row Address Strobe
CS	Chip Select
VCC	Power Supply (+ 5 V)
VSS	Ground
NC	No Connection

This document contains information on a new product. Specifications and information herein are subject to change without notice.

BLOCK DIAGRAM

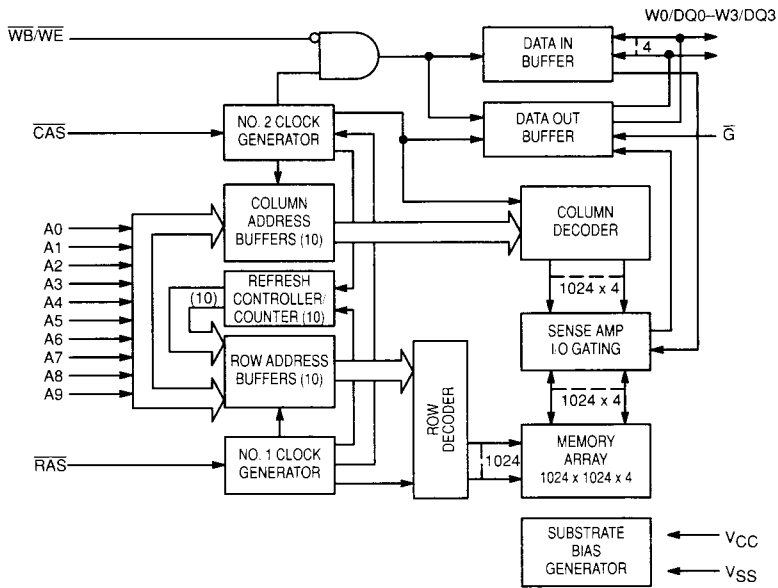

ABSOLUTE MAXIMUM RATING (See Note)

Rating	Symbol	Value	Unit
Power Supply Voltage	V_{CC}	-1 to +7	V
Voltage Relative to V_{SS} for Any Pin Except V_{CC}	V_{in}, V_{out}	-1 to +7	V
Data Out Current	I_{out}	50	mA
Power Dissipation	P_D	700	mW
Operating Temperature Range	T_A	0 to +70	°C
Storage Temperature Range	T_{stg}	-55 to +150	°C

This device contains circuitry to protect the inputs against damage due to high static voltages or electric fields; however, it is advised that normal precautions be taken to avoid application of any voltage higher than maximum rated voltages to this high-impedance circuit.

NOTE: Permanent device damage may occur if ABSOLUTE MAXIMUM RATINGS are exceeded. Functional operation should be restricted to RECOMMENDED OPERATING CONDITIONS. Exposure to higher than recommended voltages for extended periods of time could affect device reliability.

WRITE-PER-BIT MODE

The write-per-bit mode allows selective masking of a write operation on a particular set of device DQs for a given cycle. The write-per-bit function is enabled by holding the WB/WE signal "Low" at the falling edge of RAS for the minimum hold time. Masked DQs are selected by holding Data in (Di) "Low" on the falling edge of RAS for the minimum hold time. Data is then written into the device only on the unmasked DQs, which occurs on the falling edge of either WB/WE (late write) or CAS (early write). Any combination of DQs can be selectively

masked for each write cycle. The truth table for the write-per-bit function is shown in the following table:

At the Falling Edge of RAS			Function
CAS	WB/WE	DQi	
H	H	H	Write Enabled
H	H	L	Write Enabled
H	L	H	Write Enabled
H	L	L	Write Masked

DC OPERATING CONDITIONS AND CHARACTERISTICS

(V_{CC} = 5.0 V ±10%, T_A = 0 to 70°C, Unless Otherwise Noted)

RECOMMENDED OPERATING CONDITIONS

Parameter	Symbol	Min	Typ	Max	Unit	Notes
Supply Voltage (Operating Voltage Range)	V _{CC}	4.5	5.0	5.5	V	1
	V _{SS}	0	0	0		
Logic High Voltage, All Inputs	V _{IH}	2.4	—	6.5	V	1
Logic Low Voltage, All Inputs	V _{IL}	-1.0	—	0.8	V	1

DC CHARACTERISTICS

Characteristic	Symbol	Min	Max	Unit	Notes
V _{CC} Power Supply Current MCM54410A-60, t _{RC} = 110 ns MCM54410A-70, t _{RC} = 130 ns MCM54410A-80, t _{RC} = 150 ns	I _{CC1}	—	120 100 85	mA	2, 3
V _{CC} Power Supply Current (Standby) ($\overline{RAS} = \overline{CAS} = V_{IH}$)	I _{CC2}	—	2.0		
V _{CC} Power Supply Current During \overline{RAS} Only Refresh Cycles ($\overline{CAS} = V_{IH}$) MCM54410A-60, t _{RC} = 110 ns MCM54410A-70, t _{RC} = 130 ns MCM54410A-80, t _{RC} = 150 ns	I _{CC3}	—	120 100 85	mA	2, 3
V _{CC} Power Supply Current During Fast Page Mode Cycle ($\overline{RAS} = V_{IL}$) MCM54410A-60, t _{PC} = 45 ns MCM54410A-70, t _{PC} = 45 ns MCM54410A-80, t _{PC} = 50 ns	I _{CC4}	—	70 70 60		
V _{CC} Power Supply Current (Standby) ($\overline{RAS} = \overline{CAS} = V_{CC} - 0.2$ V)	I _{CC5}	—	1.0	mA	
V _{CC} Power Supply Current During \overline{CAS} Before \overline{RAS} Refresh Cycle MCM54410A-60, t _{RC} = 110 ns MCM54410A-70, t _{RC} = 130 ns MCM54410A-80, t _{RC} = 150 ns	I _{CC6}	—	120 100 85	mA	2
Input Leakage Current (0 V ≤ V _{in} ≤ 6.5 V)	I _{lk(I)}	-10	10		
Output Leakage Current ($\overline{CAS} = V_{IH}$, 0 V ≤ V _{out} ≤ 5.5 V)	I _{lk(O)}	-10	10	μA	
Output High Voltage (I _{OH} = -5 mA)	V _{OH}	2.4	—	V	
Output Low Voltage (I _{OL} = 4.2 mA)	V _{OL}	—	0.4	V	

CAPACITANCE (f = 1.0 MHz, T_A = 25°C, V_{CC} = 5 V, Periodically Sampled Rather Than 100% Tested)

Parameter	Symbol	Max	Unit	Notes
Input Capacitance	A0-A9 C _{in}	5	pF	4
	G, \overline{RAS} , \overline{CAS} , $\overline{WB/WE}$	7		
I/O Capacitance ($\overline{CAS} = V_{IH}$ to Disable Output)	W0/DQ0-W3/DQ3 C _{I/O}	7	pF	4

NOTES:

- All voltages referenced to V_{SS}.
- Current is a function of cycle rate and output loading; maximum currents are specified cycle time (minimum) with the output open.
- Column address can be changed once or less while $\overline{RAS} = V_{IL}$ and $\overline{CAS} = V_{IH}$.
- Capacitance measured with a Boonton Meter or effective capacitance calculated from the equation: C = IΔV/ΔV.

AC OPERATING CONDITIONS AND CHARACTERISTICS

(V_{CC} = 5.0 V ±10%, T_A = 0 to 70°C, Unless Otherwise Noted)

READ, WRITE, AND READ-WRITE CYCLES (See Notes 1, 2, 3, and 4)

Parameter	Symbol		54410A-60		54410A-70		54410A-80		Unit	Notes
	Std	Alt	Min	Max	Min	Max	Min	Max		
Random Read or Write Cycle Time	t _{RELR}	t _{RC}	110	—	130	—	150	—	ns	5
Read-Write Cycle Time	t _{RELR}	t _{RWC}	165	—	185	—	205	—	ns	5
Fast Page Mode Cycle Time	t _{CELC}	t _{PC}	45	—	45	—	50	—	ns	
Fast Page Mode Read-Write Cycle Time	t _{CELC}	t _{PRWC}	100	—	100	—	105	—	ns	
Access Time from $\overline{\text{RAS}}$	t _{RELQV}	t _{RAC}	—	60	—	70	—	80	ns	6, 7
Access Time from $\overline{\text{CAS}}$	t _{CELQV}	t _{CAC}	—	20	—	20	—	20	ns	6, 8
Access Time from Column Address	t _{AVQV}	t _{AA}	—	30	—	35	—	40	ns	6, 9
Access Time from Precharge $\overline{\text{CAS}}$	t _{CEHQV}	t _{CPA}	—	40	—	40	—	45	ns	6
$\overline{\text{CAS}}$ to Output in Low-Z	t _{CELQX}	t _{CLZ}	0	—	0	—	0	—	ns	6
Output Buffer and Turn-Off Delay	t _{CEHQZ}	t _{OFF}	0	20	0	20	0	20	ns	10
Transition Time (Rise and Fall)	t _T	t _T	3	50	3	50	3	50	ns	
$\overline{\text{RAS}}$ Precharge Time	t _{REHREL}	t _{RP}	40	—	50	—	60	—	ns	
$\overline{\text{RAS}}$ Pulse Width	t _{RELREH}	t _{RAS}	60	10 k	70	10 k	80	10 k	ns	
$\overline{\text{RAS}}$ Pulse Width (Fast Page Mode)	t _{RELREH}	t _{RASP}	60	200 k	70	200 k	80	200 k	ns	
$\overline{\text{RAS}}$ Hold Time	t _{CELREH}	t _{RSH}	20	—	20	—	20	—	ns	
$\overline{\text{CAS}}$ Hold Time	t _{RELCEH}	t _{CSH}	60	—	70	—	80	—	ns	
$\overline{\text{CAS}}$ Precharge to $\overline{\text{RAS}}$ Hold Time	t _{CEHREH}	t _{RHCP}	40	—	40	—	45	—	ns	
$\overline{\text{CAS}}$ Pulse Width	t _{CELCEH}	t _{CAS}	20	10 k	20	10 k	20	10 k	ns	
$\overline{\text{RAS}}$ to $\overline{\text{CAS}}$ Delay Time	t _{RELCEL}	t _{RCD}	20	40	20	50	20	60	ns	11
$\overline{\text{RAS}}$ to Column Address Delay Time	t _{RELAV}	t _{RAD}	15	30	15	35	15	40	ns	12
$\overline{\text{CAS}}$ to $\overline{\text{RAS}}$ Precharge Time	t _{CEHREL}	t _{CRP}	5	—	5	—	5	—	ns	
$\overline{\text{CAS}}$ Precharge Time	t _{CEHCEL}	t _{CP}	10	—	10	—	10	—	ns	

(continued)

NOTES:

1. V_{IH} min and V_{IL} max are reference levels for measuring timing of input signals. Transition times are measured between V_{IH} and V_{IL}.
2. An initial pause of 200 μs is required after power-up followed by 8 $\overline{\text{RAS}}$ cycles before proper device operation is guaranteed.
3. The transition time specification applies for all input signals. In addition to meeting the transition rate specification, all input signals must transition between V_{IH} and V_{IL} (or between V_{IL} and V_{IH}) in a monotonic manner.
4. AC measurements t_T = 5.0 ns.
5. The specifications for t_{RC} (min) and t_{RWC} (min) are used only to indicate cycle time at which proper operation over the full temperature range (0°C ≤ T_A ≤ 70°C) is ensured.
6. Measured with a current load equivalent to 2 TTL (– 200 μA, + 4 mA) loads and 100 pF with the data output trip points set at V_{OH} = 2.0 V and V_{OL} = 0.8 V.
7. Assumes that t_{RCD} ≤ t_{RCD} (max).
8. Assumes that t_{RCD} ≥ t_{RCD} (max).
9. Assumes that t_{RAD} ≥ t_{RAD} (max).
10. t_{OFF} (max) and/or t_{GZ} (max) define the time at which the output achieves the open circuit condition and is not referenced to output voltage levels.
11. Operation within the t_{RCD} (max) limit ensures that t_{RAC} (max) can be met. t_{RCD} (max) is specified as a reference point only; if t_{RCD} is greater than the specified t_{RCD} (max) limit, then access time is controlled exclusively by t_{CAC}.
12. Operation within the t_{RAD} (max) limit ensures that t_{RAC} (max) can be met. t_{RAD} (max) is specified as a reference point only; if t_{RAD} is greater than the specified t_{RAD} (max) limit, then access time is controlled exclusively by t_{AA}.

READ, WRITE, AND READ-WRITE CYCLES (Continued)

Parameter	Symbol		54410A-60		54410A-70		54410A-80		Unit	Notes
	Std	Alt	Min	Max	Min	Max	Min	Max		
Row Address Setup Time	t _{AVREL}	t _{ASR}	0	—	0	—	0	—	ns	
Row Address Hold Time	t _{RELAX}	t _{RAH}	10	—	10	—	10	—	ns	
Column Address Setup Time	t _{AVCEL}	t _{ASC}	0	—	0	—	0	—	ns	
Column Address Hold Time	t _{CELAX}	t _{CAH}	15	—	15	—	15	—	ns	
Column Address to RAS Lead Time	t _{AVREH}	t _{RAL}	30	—	35	—	40	—	ns	
Read Command Setup Time	t _{WHCEL}	t _{RCS}	0	—	0	—	0	—	ns	
Read Command Hold Time Referenced to CAS	t _{CEHWX}	t _{RCH}	0	—	0	—	0	—	ns	13
Read Command Hold Time Referenced to RAS	t _{REHWX}	t _{RRH}	0	—	0	—	0	—	ns	13
Write Command Hold Time Referenced to CAS	t _{CELWH}	t _{WCH}	10	—	15	—	15	—	ns	
Write Command Pulse Width	t _{WLWH}	t _{WP}	10	—	15	—	15	—	ns	
Write Command to RAS Lead Time	t _{WLREH}	t _{RWL}	20	—	20	—	20	—	ns	
Write Command to CAS Lead Time	t _{WLCEH}	t _{CWL}	20	—	20	—	20	—	ns	
Data in Setup Time	t _{DVCEL}	t _{DS}	0	—	0	—	0	—	ns	14
Data in Hold Time	t _{CELDX}	t _{DH}	15	—	15	—	15	—	ns	14
Refresh Period	t _{RVRV}	t _{RFSH}	—	16	—	16	—	16	ms	
Write Command Setup Time	t _{WLCEL}	t _{WCS}	0	—	0	—	0	—	ns	15
CAS to Write Delay	t _{CELWL}	t _{CWD}	50	—	50	—	50	—	ns	15
RAS to Write Delay	t _{RELWL}	t _{RWD}	90	—	100	—	110	—	ns	15
Column Address to Write Delay Time	t _{AVWL}	t _{AWD}	60	—	65	—	70	—	ns	15
CAS Precharge to Write Delay Time (Page Mode)	t _{CEHWL}	t _{CPWD}	70	—	70	—	75	—	ns	15
CAS Setup Time for CAS Before RAS Refresh	t _{RELCEL}	t _{CSR}	5	—	5	—	5	—	ns	
CAS Hold Time for CAS Before RAS Refresh	t _{RELCEH}	t _{CHR}	15	—	15	—	15	—	ns	
RAS Precharge to CAS Active Time	t _{REHCEL}	t _{RPC}	0	—	0	—	0	—	ns	
CAS Precharge Time for CAS Before RAS Counter Test	t _{CEHCEL}	t _{CPT}	30	—	40	—	40	—	ns	
RAS Hold Time Referenced to \bar{G}	t _{GLREH}	t _{ROH}	10	—	10	—	10	—	ns	
\bar{G} Access Time	t _{GLQV}	t _{GA}	—	20	—	20	—	20	ns	
\bar{G} to Data Delay	t _{GLHDX}	t _{GD}	20	—	20	—	20	—	ns	
Output Buffer Turn-Off Delay Time from \bar{G}	t _{GHQZ}	t _{GZ}	0	20	0	20	0	20	ns	10

(continued)

NOTES:

13. Either t_{RRH} or t_{RCH} must be satisfied for a read cycle.
14. These parameters are referenced to CAS leading edge in early write cycles and to \bar{W} leading edge in late write or read-write cycles.
15. t_{WCS}, t_{RWD}, t_{CWD}, t_{AWD}, and t_{CPWD} are not restrictive operating parameters. They are included in the data sheet as electrical characteristics only; if t_{WCS} ≥ t_{WCS} (min), the cycle is an early write cycle and the data out pin will remain open circuit (high impedance) throughout the entire cycle; if t_{CWD} ≥ t_{CWD} (min), t_{RWD} ≥ t_{RWD} (min), t_{AWD} ≥ t_{AWD} (min), and t_{CPWD} ≥ t_{CPWD} (min) (page mode), the cycle is a read-write cycle and the data out will contain data read from the selected cell. If neither of these sets of conditions is satisfied, the condition of the data out (at access time) is indeterminate.

READ, WRITE, AND READ-WRITE CYCLES (Continued)

Parameter	Symbol		54410A-60		54410A-70		54410A-80		Unit	Notes
	Std	Alt	Min	Max	Min	Max	Min	Max		
\overline{G} Command Hold Time	t _{WLGL}	t _{GH}	20	—	20	—	20	—	ns	
Write Command Setup Time (Test Mode)	t _{WLREL}	t _{WTS}	10	—	10	—	10	—	ns	
Write Command Hold Time (Test Mode)	t _{RELWH}	t _{WTH}	10	—	10	—	10	—	ns	
Write to \overline{RAS} Precharge Time (\overline{CAS} Before \overline{RAS} Refresh)	t _{WHREL}	t _{WRP}	10	—	10	—	10	—	ns	
Write to \overline{RAS} Hold Time (\overline{CAS} Before \overline{RAS} Refresh)	t _{RELWL}	t _{WRH}	10	—	10	—	10	—	ns	
Write Per Bit Setup Time	t _{WBVREL}	t _{WBS}	0	—	0	—	0	—	ns	
Write Per Bit Hold Time	t _{RELWBV}	t _{WBH}	10	—	10	—	10	—	ns	
Write Per Bit Selection Setup Time	t _{WDVREL}	t _{WDS}	0	—	0	—	0	—	ns	
Write Per Bit Selection Hold Time	t _{RELWDV}	t _{WDH}	10	—	10	—	10	—	ns	

\bar{G} CONTROLLED WRITE CYCLE

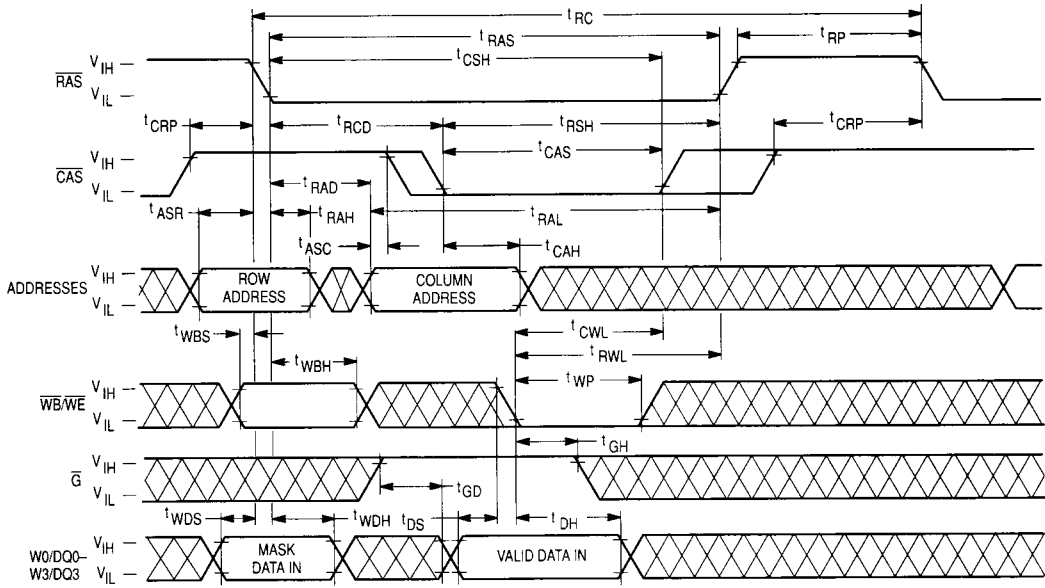

READ-WRITE CYCLE

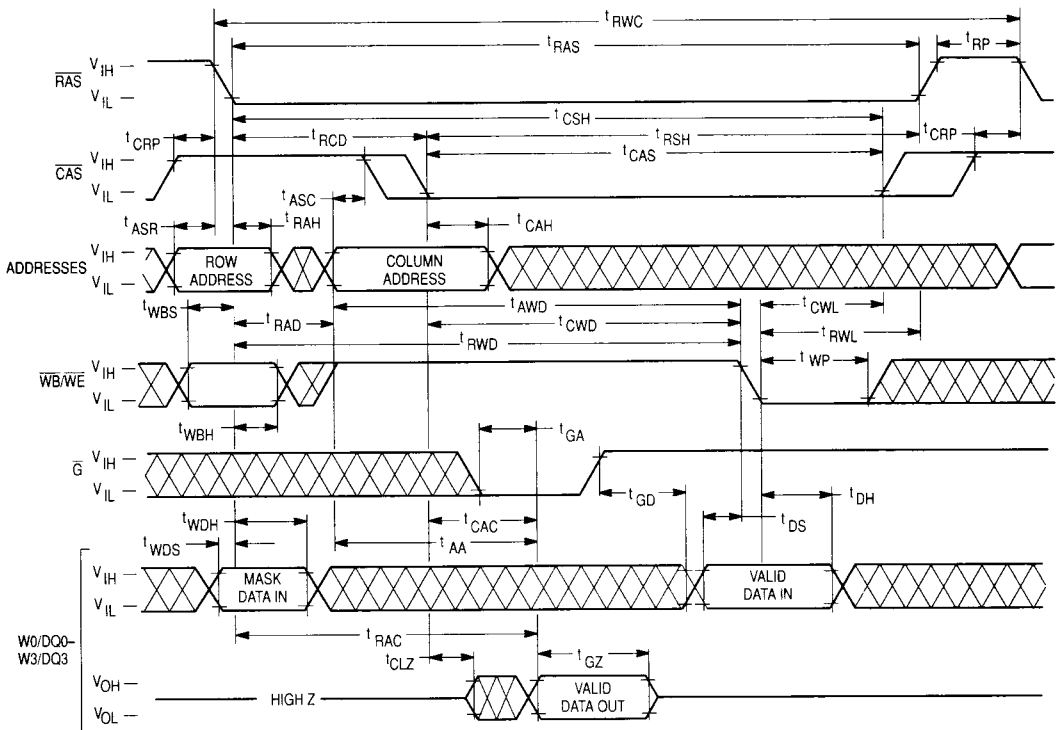

FAST PAGE MODE READ CYCLE

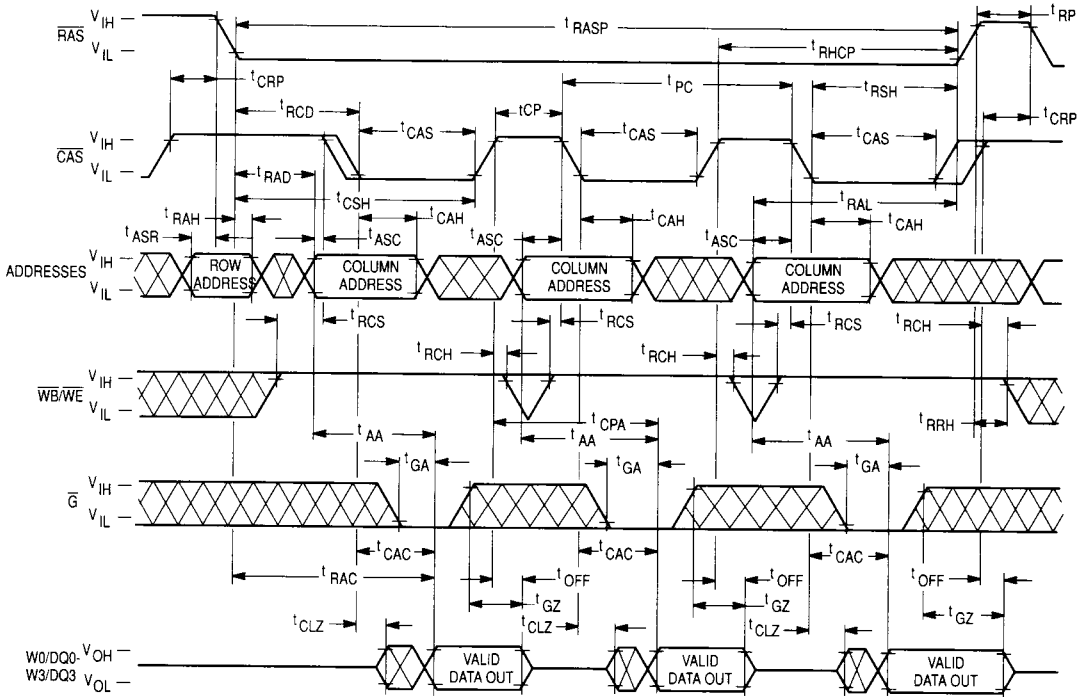

FAST PAGE MODE EARLY WRITE CYCLE

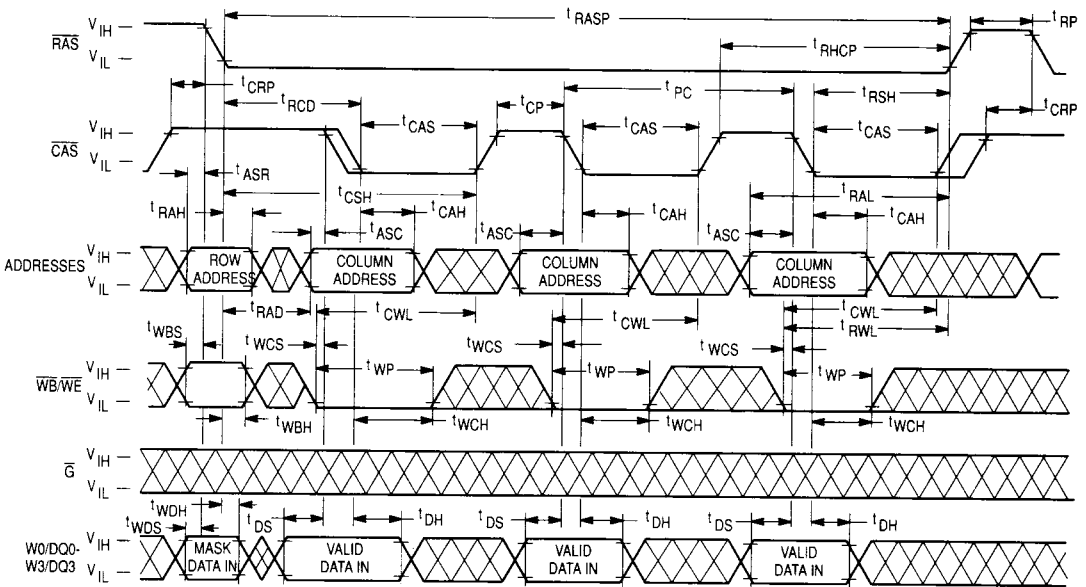

RAS ONLY REFRESH CYCLE
(WB/WE and \bar{G} are Don't Care)

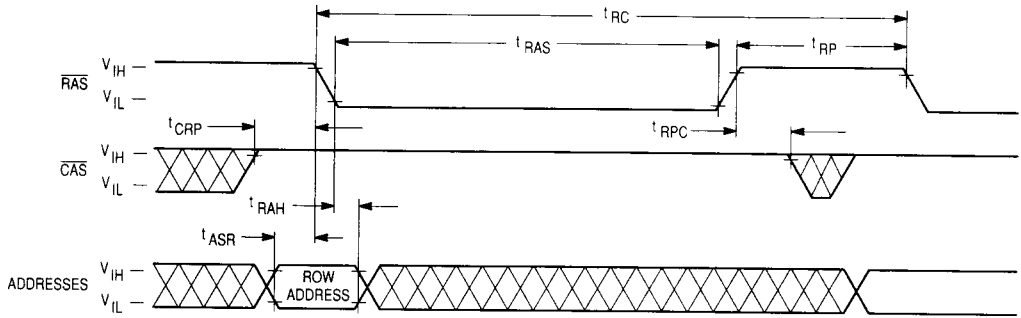

CAS BEFORE RAS REFRESH CYCLE
(\bar{G} and A0-A9 are Don't Care)

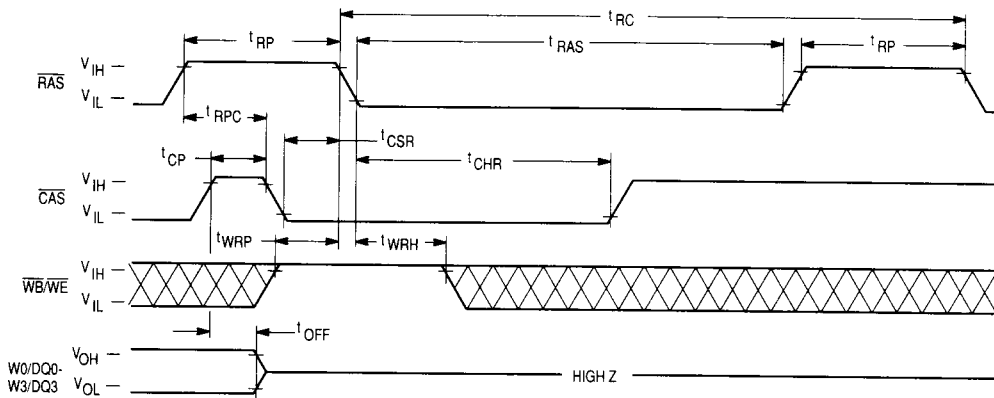

HIDDEN REFRESH CYCLE (READ)

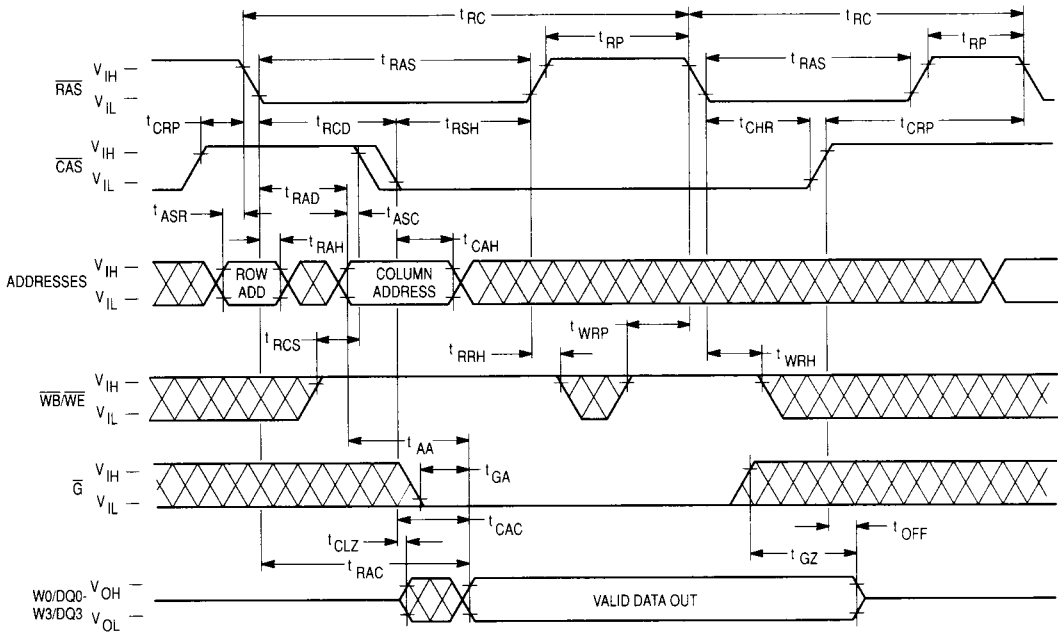

HIDDEN REFRESH CYCLE (EARLY WRITE)

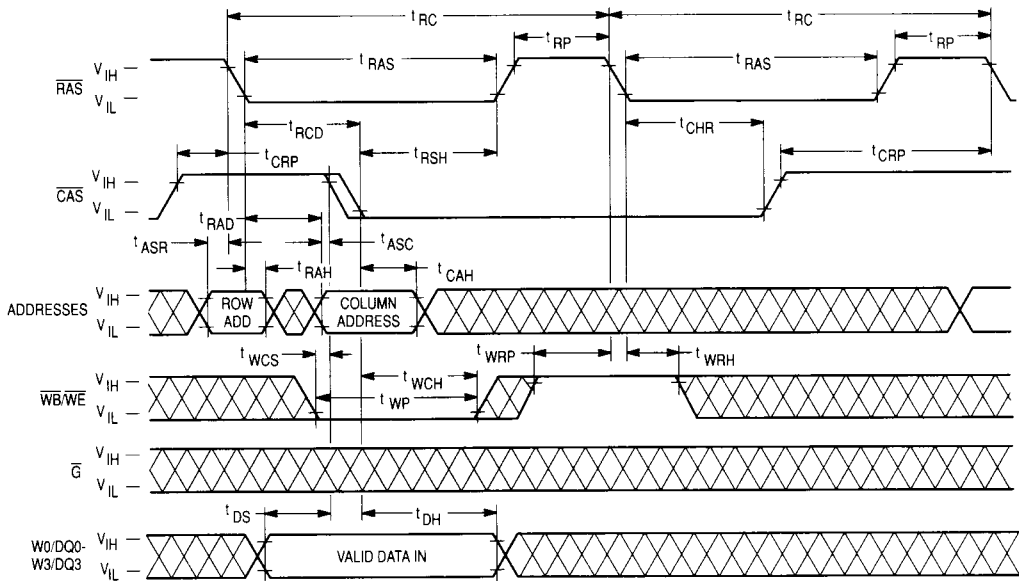

CAS BEFORE RAS REFRESH COUNTER TEST CYCLE

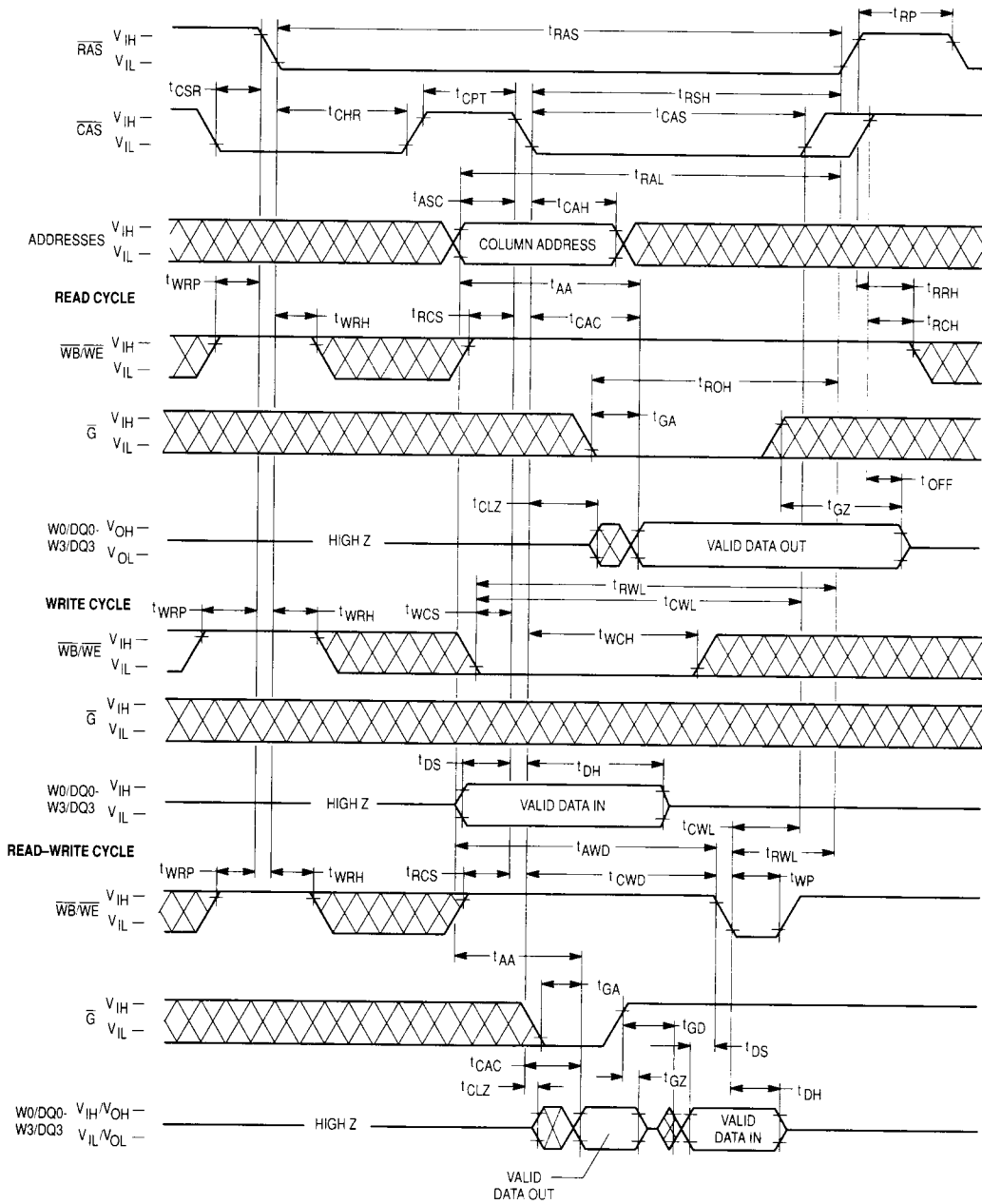

DEVICE INITIALIZATION

On power-up an initial pause of 200 microseconds is required for the internal substrate generator to establish the correct bias voltage. This must be followed by a minimum of eight active cycles of the row address strobe (clock) to initialize all dynamic nodes within the RAM. During an extended inactive state (greater than 16 milliseconds with the device powered up), a wakeup sequence of eight active cycles is necessary to ensure proper operation.

ADDRESSING THE RAM

The ten address pins on the device are time multiplexed at the beginning of a memory cycle by two clocks, row address strobe ($\overline{\text{RAS}}$) and column address strobe ($\overline{\text{CAS}}$), into two separate 10-bit address fields. A total of twenty address bits, ten rows and ten columns, will decode one of the 1,048,576 bit locations in the device. $\overline{\text{RAS}}$ active transition is followed by $\overline{\text{CAS}}$ active transition (active = V_{IL} , t_{RCD} minimum) for all read or write cycles. The delay between $\overline{\text{RAS}}$ and $\overline{\text{CAS}}$ active transitions, referred to as the **multiplex window**, gives a system designer flexibility in setting up the external addresses into the RAM.

The external $\overline{\text{CAS}}$ signal is ignored until an internal $\overline{\text{RAS}}$ signal is available. This "gate" feature on the external $\overline{\text{CAS}}$ clock enables the internal $\overline{\text{CAS}}$ line as soon as the row address hold time (t_{RAH}) specification is met (and defines t_{RCD} minimum). The multiplex window can be used to absorb skew delays in switching the address bus from row to column addresses and in generating the $\overline{\text{CAS}}$ clock.

There are three other variations in addressing the 1Mx4 RAM: **$\overline{\text{RAS}}$ only refresh cycle**, **$\overline{\text{CAS}}$ before $\overline{\text{RAS}}$ refresh cycle**, and **page mode**. All three are discussed in separate sections that follow.

READ CYCLE

The DRAM may be read with four different cycles: "normal" random read cycle, page mode read cycle, read-write cycle, and page mode read-write cycle. The normal read cycle is outlined here, while the other cycles are discussed in separate sections.

The normal read cycle begins as described in **ADDRESSING THE RAM**, with $\overline{\text{RAS}}$ and $\overline{\text{CAS}}$ active transitions latching the desired bit location. The write ($\overline{\text{WB}}/\overline{\text{WE}}$) input level must be high (V_{IH}), t_{RCS} (minimum) before the $\overline{\text{CAS}}$ active transition, to enable read mode.

Both the $\overline{\text{RAS}}$ and $\overline{\text{CAS}}$ clocks trigger a sequence of events which are controlled by several delayed internal clocks. The internal clocks are linked in such a manner that the read access time of the device is independent of the address multiplex window. Both $\overline{\text{CAS}}$ and output enable ($\overline{\text{G}}$) control read access time: $\overline{\text{CAS}}$ must be active before or at t_{RCD} maximum and $\overline{\text{G}}$ must be active $t_{RAC}-t_{GA}$ (both minimum) after $\overline{\text{RAS}}$ active transition to guarantee valid data out (Q) at t_{RAC} (access time from $\overline{\text{RAS}}$ active transition). If the t_{RCD} maximum is exceeded and/or $\overline{\text{G}}$ active transition does not occur in time, read access time is determined by either the $\overline{\text{CAS}}$ or $\overline{\text{G}}$ clock active transition (t_{CAC} or t_{GA}).

The $\overline{\text{RAS}}$ and $\overline{\text{CAS}}$ clocks must remain active for a minimum time of t_{RAS} and t_{CAS} respectively, to complete the read cycle. $\overline{\text{WB}}/\overline{\text{WE}}$ must remain high throughout the cycle, and for time t_{RRH} or t_{RCH} after $\overline{\text{RAS}}$ or $\overline{\text{CAS}}$ inactive transition, respectively, to maintain the data at that bit location. Once $\overline{\text{RAS}}$ transitions to inactive, it must remain inactive for a minimum

time of t_{PP} to precharge the internal device circuitry for the next active cycle. Q is valid, but not latched, as long as the $\overline{\text{CAS}}$ and $\overline{\text{G}}$ clocks are active. When either the $\overline{\text{CAS}}$ or $\overline{\text{G}}$ clock transitions to inactive, the output will switch to High Z (three-state) t_{OFF} or t_{GZ} after the inactive transition.

WRITE CYCLE

The user can write to the DRAM with any of four cycles: early write, late write, page mode early write, and page mode read-write. Early and late write modes are discussed here, while page mode write operations are covered in another section.

A write cycle begins as described in **ADDRESSING THE RAM**. Write mode is enabled by the transition of $\overline{\text{WB}}/\overline{\text{WE}}$ to active (V_{IL}). Early and late write modes are distinguished by the active transition of $\overline{\text{WB}}/\overline{\text{WE}}$, with respect to $\overline{\text{CAS}}$. Minimum active time t_{RAS} and t_{CAS} , and precharge time t_{PP} apply to write mode, as in the read mode.

An early write cycle is characterized by $\overline{\text{WB}}/\overline{\text{WE}}$ active transition at minimum time t_{WCS} before $\overline{\text{CAS}}$ active transition. Data in (D) is referenced to $\overline{\text{CAS}}$ in an early write cycle. $\overline{\text{RAS}}$ and $\overline{\text{CAS}}$ clocks must stay active for t_{RWL} and t_{CWL} , respectively, after the start of the early write operation to complete the cycle.

Q remains in three-state condition throughout an early write cycle because $\overline{\text{WB}}/\overline{\text{WE}}$ active transition precedes or coincides with $\overline{\text{CAS}}$ active transition, keeping data-out buffers and $\overline{\text{G}}$ disabled.

A late write cycle (referred to as $\overline{\text{G}}$ -controlled write) occurs when $\overline{\text{WB}}/\overline{\text{WE}}$ active transition is made after $\overline{\text{CAS}}$ active transition. $\overline{\text{WB}}/\overline{\text{WE}}$ active transition could be delayed for almost 10 microseconds after $\overline{\text{CAS}}$ active transition, ($t_{RCD} + t_{CWD} + t_{RWL} + 2t_T$) $\leq t_{RAS}$, if other timing minimums (t_{RCD} , t_{RWL} , and t_T) are maintained. D is referenced to $\overline{\text{WB}}/\overline{\text{WE}}$ active transition in a late write cycle. Output buffers are enabled by $\overline{\text{CAS}}$ active transition but outputs are switched off by $\overline{\text{G}}$ inactive transition, which is required to write to the device. Q may be indeterminate—see note 15 of ac operating conditions table. $\overline{\text{RAS}}$ and $\overline{\text{CAS}}$ must remain active for t_{RWL} and t_{CWL} , respectively, after $\overline{\text{WB}}/\overline{\text{WE}}$ active transition to complete the write cycle. $\overline{\text{G}}$ must remain inactive for t_{GH} after $\overline{\text{WB}}/\overline{\text{WE}}$ active transition to complete the write cycle.

READ-WRITE CYCLE

A read-write cycle performs a read and then a write at the same address, during the same cycle. This cycle is basically a late write cycle, as discussed in the **WRITE CYCLE** section, except $\overline{\text{WB}}/\overline{\text{WE}}$ must remain high for t_{CWD} minimum after the $\overline{\text{CAS}}$ active transition, to guarantee valid Q before writing the bit.

PAGE MODE CYCLES

Page mode allows fast successive data operations at all 1024 column locations on a selected row of the 1M x 4 dynamic RAM. Read access time in page mode (t_{CAC}) is typically half the regular $\overline{\text{RAS}}$ clock access time, t_{RAC} . Page mode operation consists of keeping $\overline{\text{RAS}}$ active while toggling $\overline{\text{CAS}}$ between V_{IH} and V_{IL} . The row is latched by $\overline{\text{RAS}}$ active transition, while each $\overline{\text{CAS}}$ active transition allows selection of a new column location on the row.

A page mode cycle is initiated by a normal read, write, or read-write cycle, as described in prior sections. Once the timing requirements for the first cycle are met, $\overline{\text{CAS}}$ transitions to inactive for minimum t_{CP} , while $\overline{\text{RAS}}$ remains low (V_{IL}). The second $\overline{\text{CAS}}$ active transition while $\overline{\text{RAS}}$ is low initiates the first page mode cycle (t_{PC} or t_{PRWC}). Either a read, write, or

read-write operation can be performed in a page mode cycle, subject to the same conditions as in normal operation (previously described). These operations can be intermixed in consecutive page mode cycles and performed in any order. The maximum number of consecutive page mode cycles is limited by t_{RASp} . Page mode operation is ended when \overline{RAS} transitions to inactive, coincident with or following \overline{CAS} inactive transition.

REFRESH CYCLES

The dynamic RAM design is based on capacitor charge storage for each bit in the array. This charge will tend to degrade with time and temperature. Each bit must be periodically **refreshed** (recharged) to maintain the correct bit state. Bits in the MCM54410A require refresh every 16 milliseconds.

This is accomplished by cycling through the 1024 row addresses in sequence within the specified refresh time. All the bits on a row are refreshed simultaneously when the row is addressed. Distributed refresh implies a row refresh every 15.6 microseconds for the MCM54410A. Burst refresh, a refresh of all 1024 rows consecutively, must be performed every 16 milliseconds on the MCM54410A.

A normal read, write, or read-write operation to the RAM will refresh all the bits associated with the particular row decoded. Three other methods of refresh, **RAS-only refresh**, **CAS before RAS refresh**, and **hidden refresh** are available on this device for greater system flexibility.

RAS-Only Refresh

RAS-only refresh consists of \overline{RAS} transition to active, latching the row address to be refreshed, while \overline{CAS} remains high (V_{IH}) throughout the cycle. An external counter is employed to ensure all rows are refreshed within the specified limit.

CAS Before RAS Refresh

CAS before RAS refresh is enabled by bringing \overline{CAS} active before \overline{RAS} . This clock order activates an internal refresh counter that generates the row address to be refreshed. External address lines are ignored during the automatic refresh cycle. The output buffer remains at the same state it was in

during the previous cycle (hidden refresh). $\overline{WB}/\overline{WE}$ must be inactive for time t_{WRP} before and time t_{WRH} after \overline{RAS} active transition to prevent switching the device into **test mode**.

Hidden Refresh

Hidden refresh allows refresh cycles to occur while maintaining valid data at the output pin. Holding \overline{CAS} active at the end of a read or write cycle, while \overline{RAS} cycles inactive for t_{RP} and back to active, starts the hidden refresh. This is essentially the execution of a \overline{CAS} before \overline{RAS} refresh from a cycle in progress (see Figure 1). $\overline{WB}/\overline{WE}$ is subject to the same conditions with respect to \overline{RAS} active transition (to prevent test mode cycle) as in \overline{CAS} before \overline{RAS} refresh.

CAS BEFORE RAS REFRESH COUNTER TEST

The internal refresh counter of this device can be tested with a **CAS before RAS refresh counter test**. This test is performed with a read-write operation. During the test, the internal refresh counter generates the row address, while the external address supplies the column address. The entire array is refreshed after 1024 cycles, as indicated by the check data written in each row. See **CAS before RAS refresh counter test cycle timing diagram**.

The test can be performed after a minimum of eight **CAS before RAS** initialization cycles. Test procedure:

1. Write "0"s into all memory cells with normal write mode.
2. Select a column address, read "0" out and write "1" into the cell by performing the **CAS before RAS refresh counter test, read-write cycle**. Repeat this operation 1024 times.
3. Read the "1"s which were written in step 2 in normal read mode.
4. Using the same starting column address as in step 2, read "1" out and write "0" into the cell by performing the **CAS before RAS refresh counter test, read-write cycle**. Repeat this operation 1024 times.
5. Read "0"s which were written in step 4 in normal read mode.
6. Repeat steps 1 to 5 using complement data.

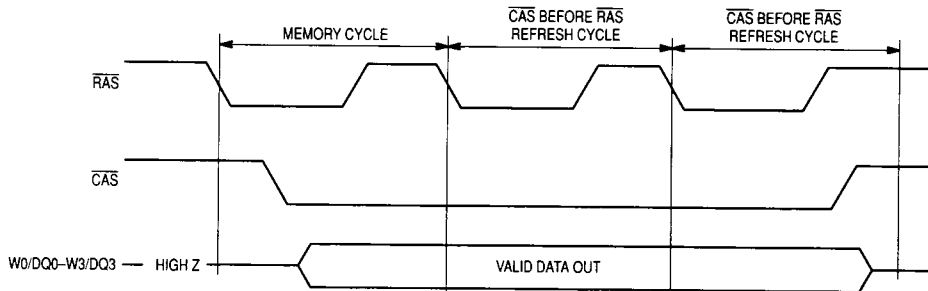

Figure 1. Hidden Refresh Cycle

TEST MODE

The internal organization of this device (512K × 8) allows it to be tested as if it were a 512K × 4 DRAM. Nineteen of the twenty addresses are used when operating the device in test mode. Column address A0 is ignored by the device in test mode. A test mode cycle reads and/or writes data to a bit in each of eight 512K blocks (B0–B7) in parallel. External data out is determined by the internal test mode logic of the device.

See the following truth table and test mode block diagram.

W, CAS before RAS timing puts the device in "Test Mode" as shown in the test mode timing diagram. A CAS before RAS or a RAS only refresh cycle puts the device back into normal mode. Refresh is performed in test mode by using a W, CAS before RAS refresh cycle which uses internal refresh address counter.

TEST MODE TRUTH TABLE

D	B0, B1	B2, B3	B4, B5	B6, B7	Q
0	0	0	0	0	1
1	1	1	1	1	1
—	Any Other				0

TEST MODE
AC OPERATING CONDITIONS AND CHARACTERISTICS
 (V_{CC} = 5.0 V ±10%, T_A = 0 to 70°C, Unless Otherwise Noted)

READ, WRITE, AND READ-WRITE CYCLES (See Notes 1, 2, 3, and 4)

Parameter	Symbol		54410A-60		54410A-70		54410A-80		Unit	Notes
	Std	Alt	Min	Max	Min	Max	Min	Max		
Random Read or Write Cycle Time	t _{RELREL}	t _{RC}	115	—	135	—	155	—	ns	5
Fast Page Mode Cycle Time	t _{CELCEL}	t _{PC}	50	—	50	—	55	—	ns	
Access Time from RAS	t _{RELQV}	t _{RAC}	—	65	—	75	—	85	ns	6, 7
Access Time from CAS	t _{CELQV}	t _{CAC}	—	25	—	25	—	25	ns	6, 8
Access Time from Column Address	t _{AVQV}	t _{AA}	—	35	—	40	—	45	ns	6, 9
Access Time from Precharge CAS	t _{CEHQV}	t _{CPA}	—	45	—	45	—	50	ns	6
RAS Pulse Width	t _{RELREH}	t _{RAS}	65	10 k	75	10 k	85	10 k	ns	
RAS Pulse Width (Fast Page Mode)	t _{RELREH}	t _{RASP}	65	200 k	75	200 k	85	200 k	ns	
RAS Hold Time	t _{CELREH}	t _{RSH}	25	—	25	—	25	—	ns	
CAS Hold Time	t _{RELCEH}	t _{CSH}	65	—	75	—	85	—	ns	
CAS Precharge to RAS Hold Time	t _{CEHREH}	t _{RHCP}	45	—	45	—	50	—	ns	
CAS Pulse Width	t _{CELCEH}	t _{CAS}	25	10 k	25	10 k	25	10 k	ns	
Column Address to RAS Lead Time	t _{AVREH}	t _{RAL}	35	—	40	—	45	—	ns	

NOTES:

- V_{IH} min and V_{IL} max are reference levels for measuring timing of input signals. Transition times are measured between V_{IH} and V_{IL}.
- An initial pause of 200 μs is required after power-up followed by 8 RAS cycles before proper device operation is guaranteed.
- The transition time specification applies for all input signals. In addition to meeting the transition rate specification, all input signals must transition between V_{IH} and V_{IL} (or between V_{IL} and V_{IH}) in a monotonic manner.
- AC measurements t_T = 5.0 ns.
- The specifications for t_{RC} (min) and t_{RWC} (min) are used only to indicate cycle time at which proper operation over the full temperature range (0°C ≤ T_A ≤ 70°C) is ensured.
- Measured with a current load equivalent to 2 TTL (–200 μA, +4 mA) loads and 100 pF with the data output trip points set at V_{OH} = 2.0 V and V_{OL} = 0.8 V.
- Assumes that t_{RCD} ≤ t_{RCD} (max).
- Assumes that t_{RCD} ≥ t_{RCD} (max).
- Assumes that t_{RAD} ≥ t_{RAD} (max).

WRITE, CAS BEFORE RAS REFRESH CYCLE (TEST MODE ENTRY)
 (D and A0-A9 are Don't Care)

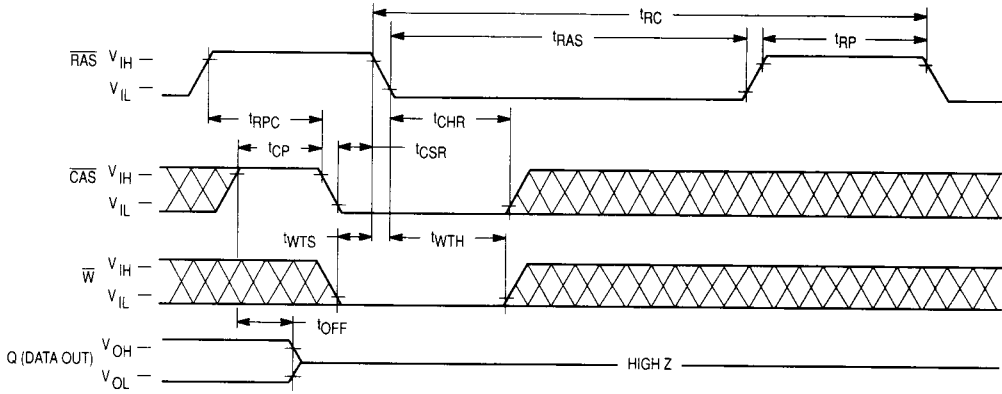

TEST MODE BLOCK DIAGRAM

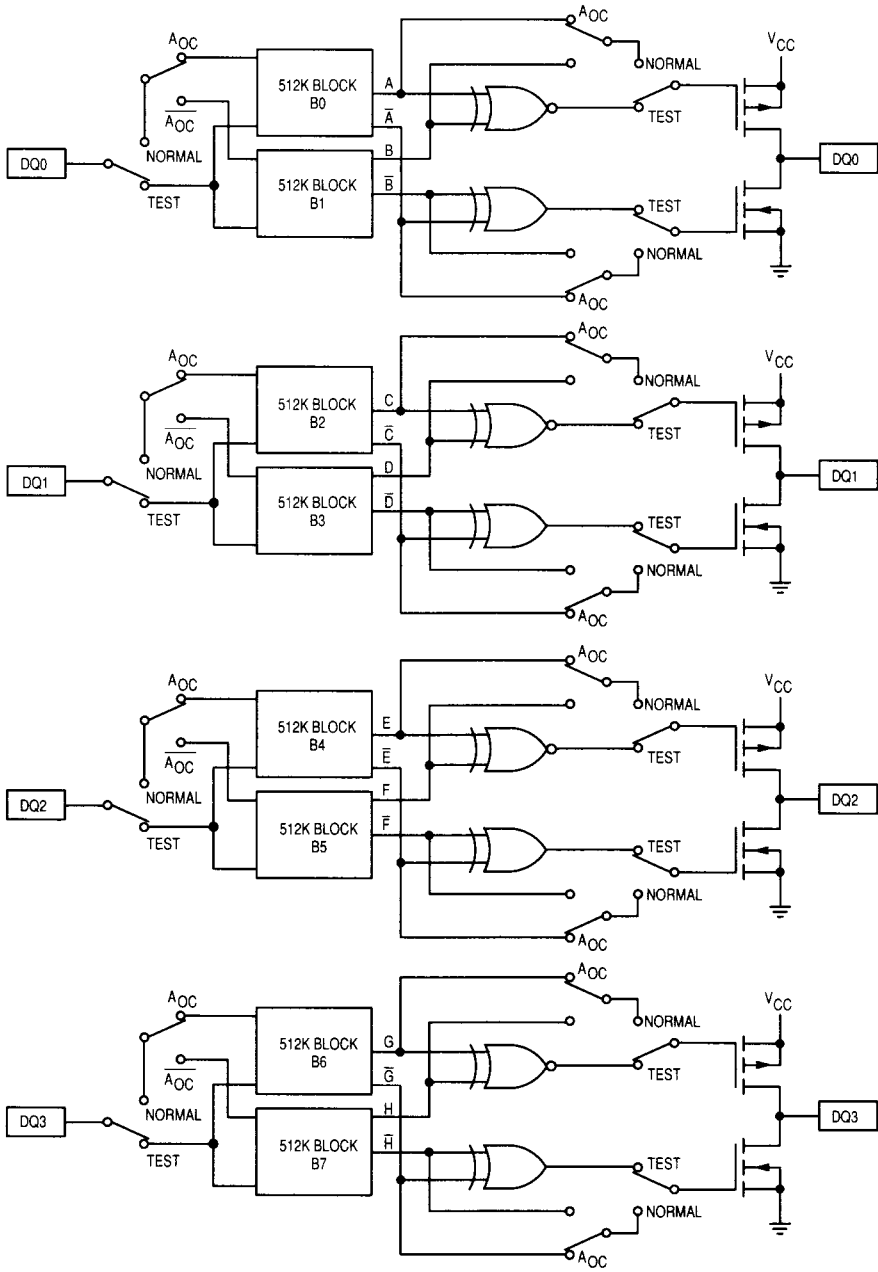

ORDERING INFORMATION
(Order by Full Part Number)

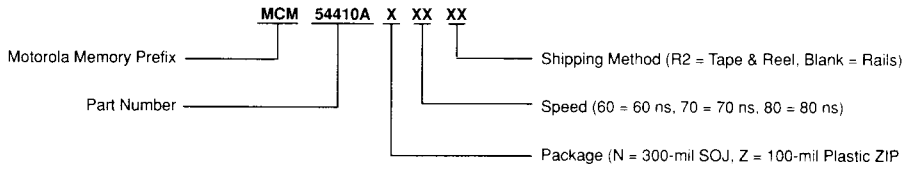

Full Part Numbers— MCM54410AN60 MCM54410AN60R2 MCM54410AZ60
 MCM54410AN70 MCM54410AN70R2 MCM54410AZ70
 MCM54410AN80 MCM54410AN80R2 MCM54410AZ80