

# PRELIMINARY SPECIFICATION



## GM71C4256 262,144 WORDS x 4 BIT CMOS DYNAMIC RAM

T-46-23-17

### Description

The GM71C4256 is the new generation dynamic RAM organized 262,144x4 Bit. The GM71C4256 utilizes GoldStar's silicon Gate process technology as well as advanced circuit techniques to provide wide operating margins, both internally and to the system user. Multiplexed address inputs permit the GM71C4256 to be packaged in a standard 20 pin DIP. The package size provides high system bit densities and is compatible with widely available automated testing and insertion equipment. System oriented features include single power supply of 5V±10% tolerance, direct interfacing capability with high performance logic families such as Schottky TTL.

### Features

- 262,144 x 4 Bit organization
- Fast access time and cycle time: 85/100/120(Max)

### Pin Configuration

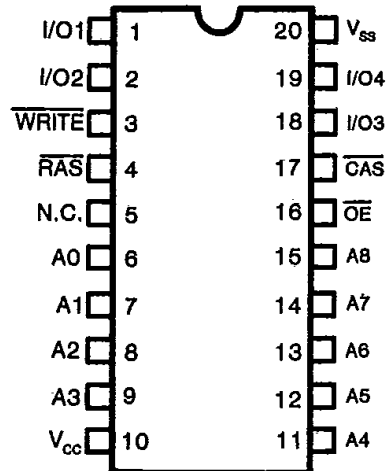

PARAMETER		GM71C4256(ns)		
		-85	-10	-12
t <sub>RAC</sub>	$\overline{RAS}$ Access Time	85	100	120
t <sub>AA</sub>	Column Address Access Time	45	50	60
t <sub>CAC</sub>	$\overline{CAS}$ Access Time	30	30	35
t <sub>RC</sub>	Cycle Time	165	190	220
t <sub>PC</sub>	Fast Page Mode Cycle Time	50	55	70

- A<sub>0</sub>-A<sub>8</sub> Address Inputs
- $\overline{RAS}$  Row Address Strobe
- $\overline{CAS}$  Column Address Strobe
- $\overline{WRITE}$  Read/Write Input
- $\overline{OE}$  Output Enable
- I/O1~I/O4 Data Input/Output
- V<sub>CC</sub> Power (+5V)
- V<sub>SS</sub> Ground
- N.C. No Connection

- Single Power Supply of 5V±10% with a built-in V<sub>BB</sub> generator
- Low Power
  - 330mW MAX. Operating (GM71C4256-85)
  - 274mW MAX. Operating (GM71C4256-12)
  - 16.5mW MAX. Standby
- Output unlatched at cycle end allows two-dimensional chip selection
- Read-Modify-Write,  $\overline{RAS}$ -only refresh, and Fast Page Mode Capability
- All input and output TTL compatible
- 512 refresh cycles/8ms
- Industry standard 20 pin Plastic DIP

T-46-23-17

**GM71C4256**

**Absolute Maximum Ratings**

Input Voltage	V <sub>IN</sub>	-1~7V
Output Voltage	V <sub>OUT</sub>	-1~7V
Power Supply Voltage	V <sub>CC</sub>	-1~7V
Operating Temperature	T <sub>OPR</sub>	0~70°C
Storage Temperature	T <sub>STG</sub>	-55~150°C
Short Circuit Output Current	I <sub>OUT</sub>	50mA

(Note 1)

**Recommended DC Operating Conditions**

(T <sub>A</sub> =0°C to +70°C)	
V <sub>CC</sub> Supply Voltage	4.5~5.5V
V <sub>IH</sub> Input High Voltage	2.4~6.5V
V <sub>IL</sub> Input Low Voltage	-1.0~0.8V

(Note 2)

**Functional Block Diagram**

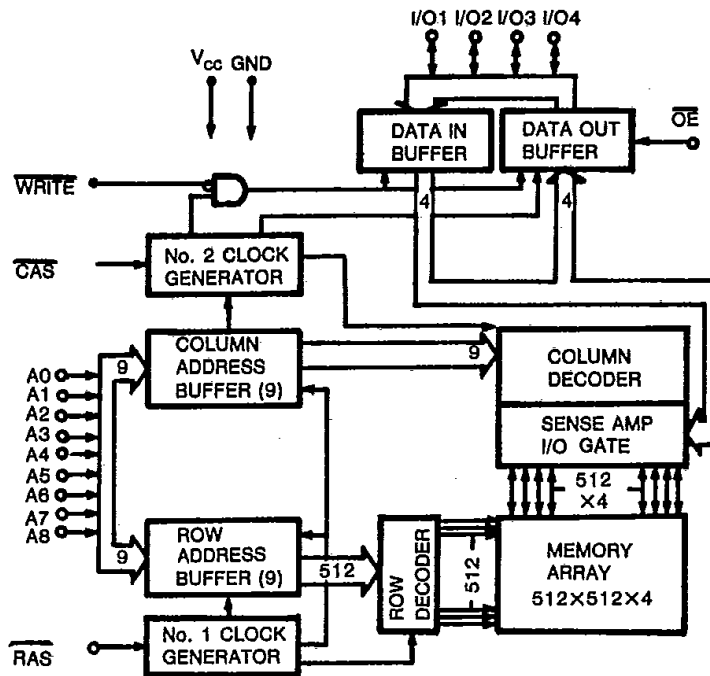

Figure 1

**GM71C4256**

**DC Electrical Characteristics:** ( $V_{CC}=5\pm 10\%$ ,  $T_A=0 \sim 70^\circ C$ )

**T-46-23-17**

SYMBOL	PARAMETER	MIN	MAX	UNIT	NOTES
$V_{OH}$	Output Level Output "H" Level Voltage ( $I_{OUT}=-5mA$ )	2.4	—	V	
$V_{OL}$	Output Level Output "L" Level Voltage ( $I_{OUT}=4.2mA$ )	—	0.4	V	
$I_{CC1}$	Operating Current	85	—	70	mA 3,4
	Average Power Supply Operating Current	100	—	65	
	( $\overline{RAS}$ , $\overline{CAS}$ , Address Cycling: $t_{RC}=t_{RC}$ MIN)	120	—	55	
$I_{CC2}$	Standby Current Power Supply Standby Current ( $\overline{RAS}=\overline{CAS}=V_{IH}$ )	—	3	mA	
$I_{CC3}$	$\overline{RAS}$ Only Refresh Current	85	—	75	mA 3
	Average Power Supply Current	100	—	65	
	$\overline{RAS}$ Only Mode ( $\overline{RAS}$ Cycling, $\overline{CAS}=V_{IH}$ ; $t_{RC}=t_{RC}$ MIN)	120	—	55	
$I_{CC4}$	Fast Page Mode Current	85	—	55	mA 3,4
	Average Power Supply Current	100	—	45	
	Fast Page Mode ( $\overline{RAS}=V_{IL}$ , $\overline{CAS}$ , Address Cycling: $t_{PC}=t_{PC}$ MIN)	120	—	35	
$I_{CC5}$	Standby Current Power Supply Standby Current ( $\overline{RAS}=\overline{CAS}=V_{CC}-0.2V$ )	—	1	mA	
$I_{I(L)}$	Input Leakage Current Any Input ( $0V \leq V_{IN} \leq 6.5V$ , All other Pins Not Under Test = 0V)	-10	10	$\mu A$	
$I_{O(L)}$	Output Leakage Current ( $D_{OUT}$ is Disabled, $0V \leq V_{OUT} \leq V_{CC}$ )	-10	10	$\mu A$	

**Capacitance** ( $V_{CC}=5V \pm 10\%$ ,  $f=1MHz$ ,  $T_A=0 \sim 70^\circ C$ )

SYMBOL	PARAMETER	MIN	MAX	UNIT
$Cl_1$	Input Capacitance (A0—A8)	—	5	pF
$Cl_2$	Input Capacitance ( $\overline{RAS}$ , $\overline{CAS}$ , $\overline{WRITE}$ , $\overline{OE}$ )	—	7	pF
$C_0$	Output Capacitance ( $I/O_1-I/O_4$ )	—	7	pF

**Electrical Characteristics And Recommended AC Operating Conditions** ( $V_{CC}=5V\pm 10\%$ ,  $T_A=0\sim 70^\circ C$ )  
(Note 5,6,7)

SYMBOL	PARAMETER	GM71C4256-85		GM71C4256-10		GM71C4256-12		UNIT	NOTES
		MIN	MAX	MIN	MAX	MIN	MAX		
$t_{RC}$	Random Read/Write Cycle Time	165	—	190	—	220	—	ns	
$t_{RMW}$	Read-Modify-Write Cycle Time	225	—	225	—	295	—	ns	
$t_{PC}$	Fast Page Mode Cycle Time	50	—	55	—	70	—	ns	
$t_{PRMW}$	Fast Page Mode Read-Modify-Write Cycle Time	110	—	115	—	140	—	ns	
$t_{RAC}$	Access Time from $\overline{RAS}$	—	85	—	100	—	120	ns	8, 13
$t_{CAC}$	Access Time from $\overline{CAS}$	—	30	—	30	—	35	ns	8, 13
$t_{AA}$	Access Time from Column Address	—	45	—	50	—	60	ns	8, 14
$t_{CPA}$	Access Time from CAS Precharge	—	45	—	50	—	65	ns	8, 14
$t_{GLZ}$	$\overline{CAS}$ to Output in Low-Z	5	—	5	—	5	—	ns	5
$t_{OFF}$	Output Buffer Turn-off Delay	0	30	0	30	0	35	ns	9
$t_T$	Transition Time (Rise and Fall)	3	50	3	50	3	50	ns	7
$t_{RP}$	$\overline{RAS}$ Precharge Time	70	—	80	—	90	—	ns	
$t_{RAS}$	$\overline{RAS}$ Pulse Width	85	10,000	100	10,000	120	10,000	ns	
$t_{RASP}$	$\overline{RAS}$ Pulse Width (Fast Page Mode)	85	100,000	100	100,000	120	100,000	ns	
$t_{RSH}$	$\overline{RAS}$ Hold Time	30	—	30	—	35	—	ns	
$t_{CSH}$	$\overline{CAS}$ Hold Time	85	—	100	—	120	—	ns	
$t_{CAS}$	$\overline{CAS}$ Pulse Width	30	10,000	30	10,000	35	10,000	ns	
$t_{RCD}$	$\overline{RAS}$ to $\overline{CAS}$ Delay Time	25	55	25	70	25	85	ns	13
$t_{RAD}$	$\overline{RAS}$ to Column Address Delay Time	20	40	20	50	20	60	ns	14
$t_{CRP}$	$\overline{CAS}$ to $\overline{RAS}$ Precharge Time	10	—	10	—	10	—	ns	
$t_{CPN}$	$\overline{CAS}$ Precharge Time	15	—	15	—	20	—	ns	
$t_{CP}$	$\overline{CAS}$ Precharge Time (Fast Page Mode)	10	—	10	—	15	—	ns	
$t_{ASR}$	Row Address Set-Up Time	0	—	0	—	0	—	ns	
$t_{RAH}$	Row Address Hold Time	15	—	15	—	15	—	ns	
$t_{ASC}$	Column Address Set-Up Time	0	—	0	—	0	—	ns	
$t_{CAH}$	Column Address Hold Time	20	—	20	—	25	—	ns	
$t_{AR}$	Column Address Hold Time Referenced to $\overline{RAS}$	65	—	75	—	90	—	ns	
$t_{RAL}$	Column Address to $\overline{RAS}$ Lead Time	45	—	50	—	60	—	ns	
$t_{RCS}$	Read Command Set-Up Time	0	—	0	—	0	—	ns	10
$t_{RCH}$	Read Command Hold Time	0	—	0	—	0	—	ns	10
$t_{RRH}$	Read Command Hold Time Referenced to $\overline{RAS}$	0	—	0	—	0	—	ns	10

T-46-23-17

**GM71C4256** $(V_{CC}=5V\pm 10\%, T_A=0\sim 70^\circ C)$  Unit: nS (Note 5,6,7)

SYMBOL	PARAMETER	GM71C4256-85		GM71C4256-10		GM71C4256-12		UNIT	NOTES
		MIN	MAX	MIN	MAX	MIN	MAX		
$t_{WCH}$	Write Command Hold Time	20	—	20	—	25	—	ns	
$t_{WCR}$	Write Command Hold Time Referenced to $\overline{RAS}$	65	—	75	—	90	—	ns	
$t_{WP}$	Write Command Pulse Width	20	—	20	—	25	—	ns	
$t_{RWL}$	Write Command to $\overline{RAS}$ Lead Time	20	—	25	—	30	—	ns	
$t_{CWL}$	Write Command to $\overline{CAS}$ Lead Time	20	—	25	—	30	—	ns	
$t_{DS}$	Data Set-Up Time	0	—	0	—	0	—	ns	11
$t_{DH}$	Data Hold Time	20	—	20	—	25	—	ns	11
$t_{DHR}$	Data Hold Time Referenced to $\overline{RAS}$	65	—	75	—	90	—	ns	
$t_{REF}$	Refresh Period	—	8	—	8	—	8	ms	
$t_{WCS}$	Write Command Set-Up Time	0	—	0	—	0	—	ns	12
$t_{CWD}$	$\overline{CAS}$ to Write Delay Time	65	—	65	—	75	—	ns	12
$t_{RWD}$	$\overline{RAS}$ to Write Delay Time	120	—	135	—	160	—	ns	12
$t_{AWD}$	Column Address to Write Delay	80	—	85	—	100	—	ns	12
$t_{RPC}$	$\overline{RAS}$ to $\overline{CAS}$ Precharge Time	0	—	0	—	0	—	ns	
$t_{ROH}$	$\overline{RAS}$ Hold Time Referenced to $\overline{OE}$	20	—	20	—	20	—	ns	
$t_{OEA}$	$\overline{OE}$ Access Time	—	25	—	25	—	30	ns	
$t_{OED}$	$\overline{OE}$ to Data Delay	25	—	25	—	30	—	ns	
$t_{OEZ}$	Output buffer turn off Delay Time from $\overline{OE}$	0	25	0	25	0	30	ns	
$t_{OEH}$	$\overline{OE}$ Command Hold Time	25	—	25	—	30	—	ns	

**Notes**

- Stresses greater than those listed under "Absolute Maximum Ratings" may cause permanent damage to the device.
- All Voltage are referenced to  $V_{SS}$ .
- $I_{CC1}$ ,  $I_{CC3}$ ,  $I_{CC4}$  depend on cycle rate.
- $I_{CC1}$ ,  $I_{CC4}$  depend on output loading. Specified values are obtained with the output open.
- An initial pause of 200 $\mu$ S is required after power-up followed by 8  $\overline{RAS}$  cycles before proper device operation is achieved..
- AC measurements assume  $t_r=5$ nS.
- $V_{IH}(\min)$  and  $V_{IL}(\max)$  are referenced levels for measuring timing of input signals. Also transition times are required between  $V_{IH}$  and  $V_{L}$ .
- Measured with a load equivalent to 2 TTL loads and 100pF.
- $t_{OFF}(\max)$  and  $t_{OEZ}(\max)$  defines the time at which the output achieves the open circuit condition and is not referenced to output voltage levels.
- Either  $t_{RCH}$  or  $t_{RRH}$  must be satisfied for a read cycle.
- These parameters are referenced to  $\overline{CAS}$  leading edge in early write cycles and to  $\overline{WRITE}$  leading edge in read-modify-write cycles.
- $t_{WCS}$ ,  $t_{RWD}$ ,  $t_{CWD}$  and  $t_{AWD}$  are not restrictive operating parameters. They are included the data sheet as electrical characteristics only. If  $t_{WCS} \geq t_{WCS}(\min)$  the cycle is early write cycle and data out pin will remain open circuit (high impedance) through the entire cycle: If  $t_{RWD} \geq t_{RWD}(\min)$ ,  $t_{CWD} \geq t_{CWD}(\min)$  and  $t_{AWD} \geq t_{AWD}(\min)$  the cycle is a read-write cycle and data out will contain data read from the selected cell: if neither or the above sets of conditions is satisfied, the condition of the data out (at access time) is indeterminate.
- Operation within the  $t_{RCD}(\max)$  limit insures that  $t_{RAC}(\max)$  can be met.  $t_{RCD}(\max)$  is specified as a referenced point only: if  $t_{RCD}$  is greater than the specified  $t_{RCD}(\max)$  limit, then access time is controlled by  $t_{RAC}$ .
- Operation within the  $t_{RAD}(\max)$  limit insures that  $t_{RAC}(\max)$  can be met.  $t_{RAD}(\max)$  is specified as a referenced point only: if  $t_{RAD}$  is greater than the specified  $t_{RAD}(\max)$  limit, then access time is controlled by  $t_{RA}$ .



**GM71C4256**

T-46-23-17

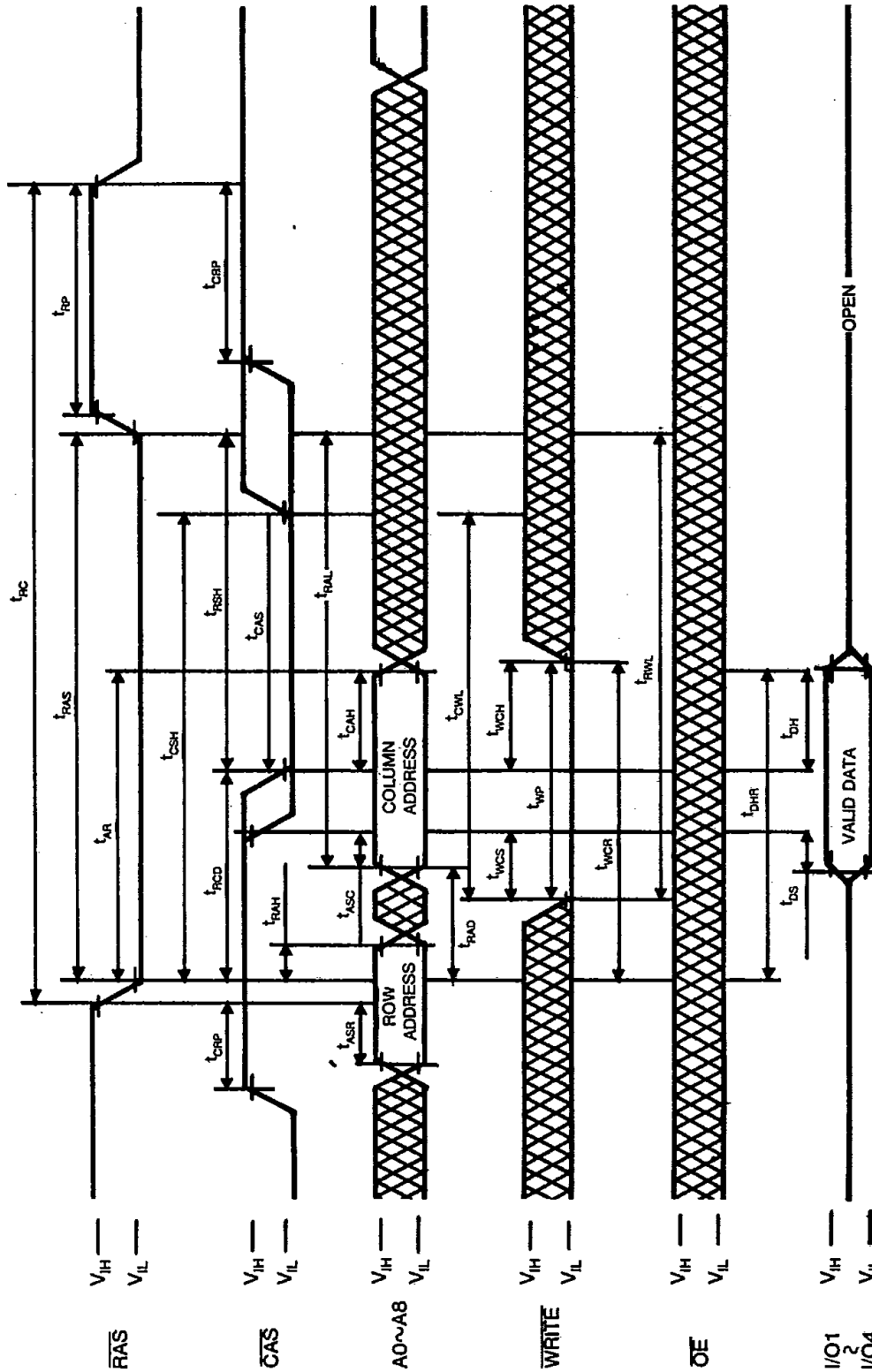

Figure 3. Write Cycle (Early Write)

**GM71C4256**

T-46-23-17

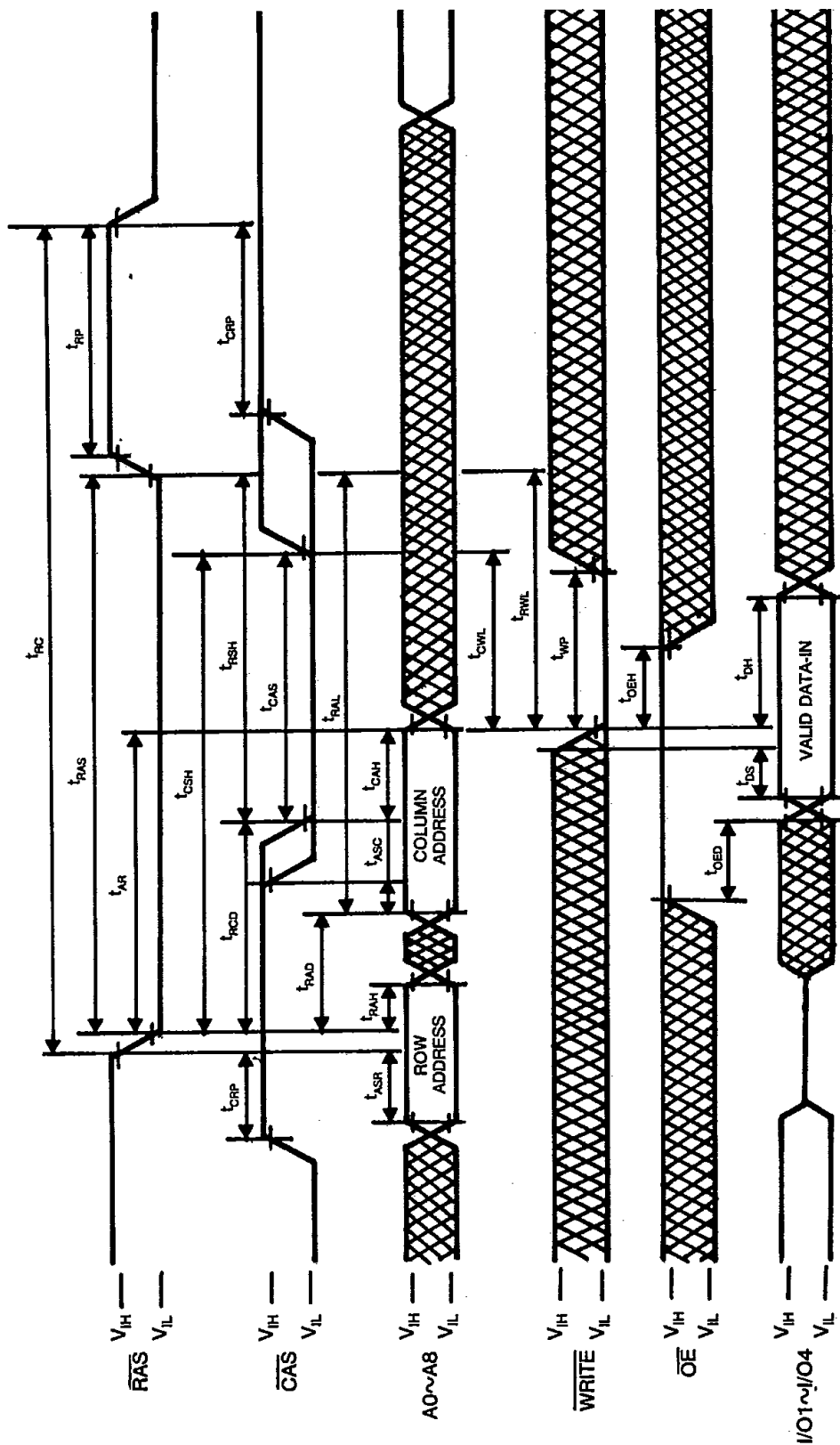

Figure 4. Write Cycle ( $\overline{OE}$  Controlled Write)





GM71C4256

T-46-23-17

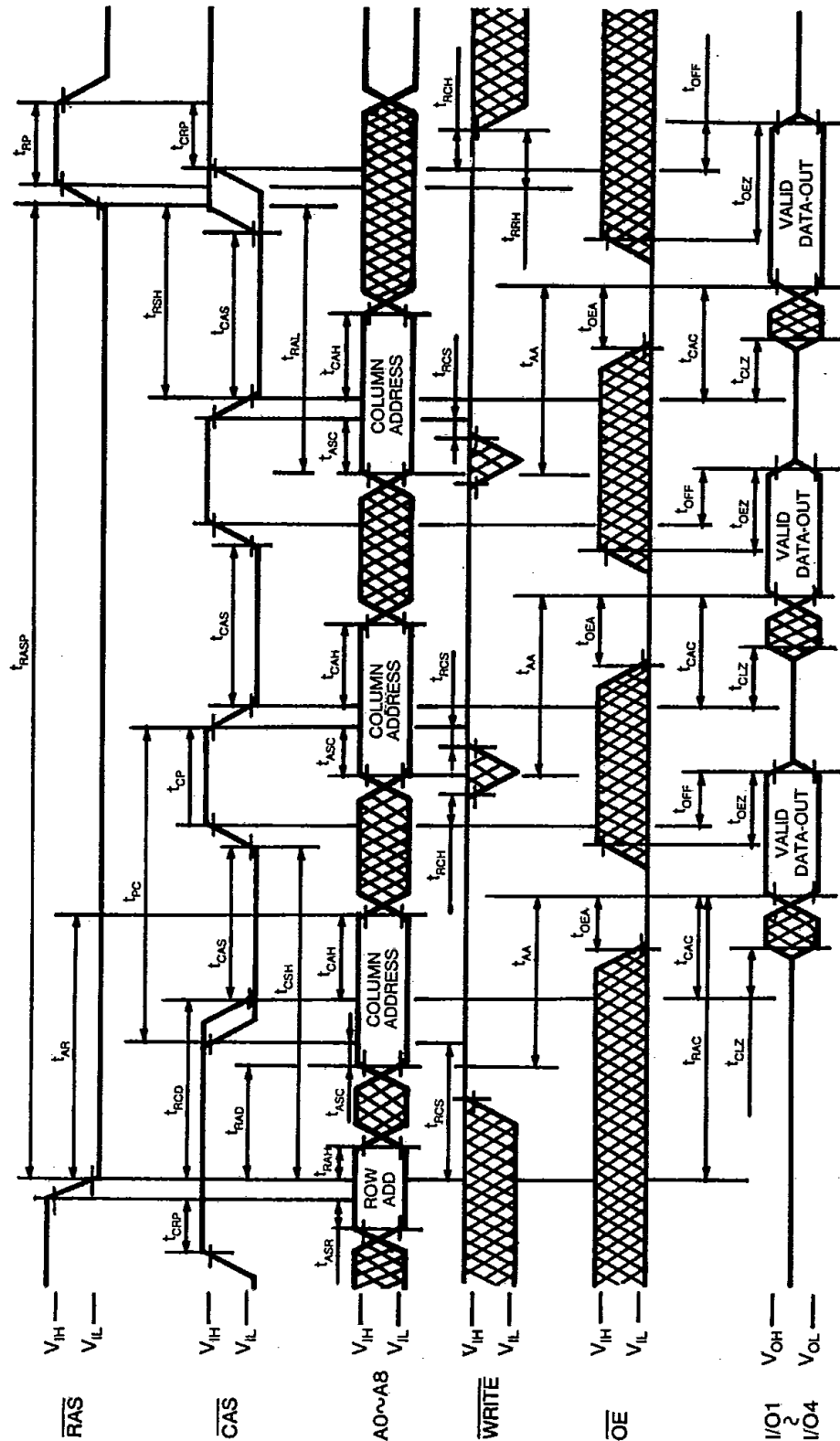

Figure 6. Fast Page Mode Read Cycle





**GM71C4256**

T-46-23-17

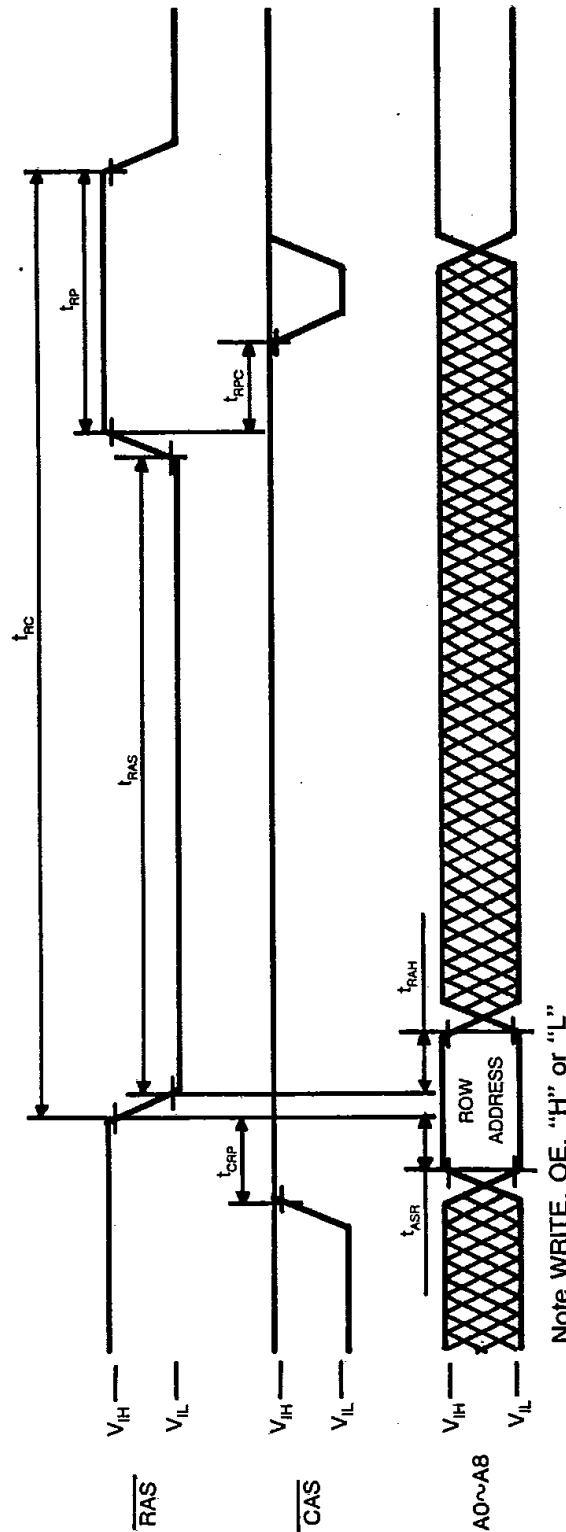

Note WRITE, OE, "H" or "L"

Figure 9.  $\overline{\text{RAS}}$  Only Refresh Cycle

# PACKAGE DIMENSION

PLASTIC DIP

T-90-20

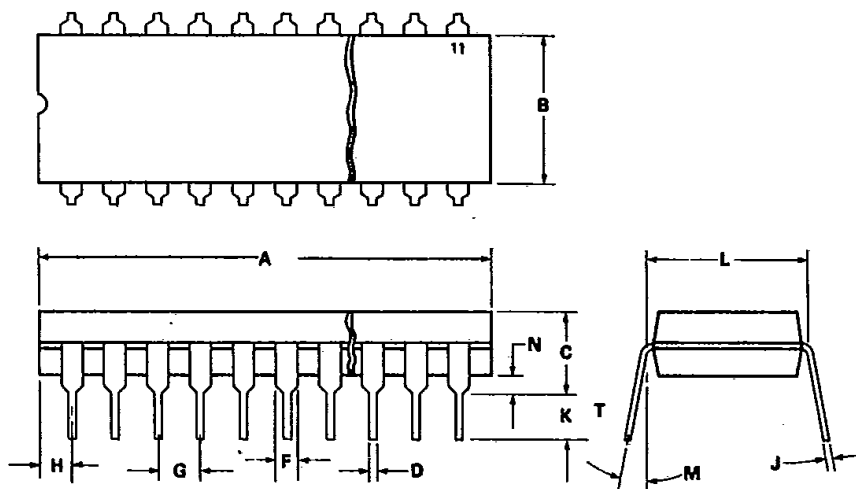

(UNIT: INCHES)

SYMBOL	16 PIN		18 PIN		20 PIN		22 PIN	
	MIN	MAX	MIN	MAX	MIN	MAX	MIN	MAX
A	0.738	0.752	0.875	0.900	1.013	1.040	1.095	1.150
B	0.245	0.255	0.245	0.255	0.263	0.273	0.260	0.287
C	0.143	0.152	0.145	0.162	0.143	0.152	0.145	0.160
D	TYP. 0.018		TYP. 0.018		TYP. 0.018		TYP. 0.018	
F	TYP. 0.063		TYP. 0.060		TYP. 0.065		TYP. 0.060	
G	0.09	0.11	0.09	0.11	0.09	0.11	0.09	0.11
H	0.015	0.030	0.04	0.05	0.058	0.066	—	0.075
J	0.009	0.014	0.009	0.015	0.009	0.010	0.009	0.010
K	0.125	0.145	0.125	0.130	0.125	0.132	0.125	0.142
L	0.300 BSC		0.300 BSC		0.300 BSC		0.300 BSC	
M	0'	10'	0'	10'	0'	10'	0'	10'
N	0.015	—	0.015	—	0.015	—	0.015	—

SYMBOL	24 PIN		28 PIN				
	MIN	MAX	MIN	MAX			
A	1.243	1.260	1.415	1.460			
B	0.535	0.545	0.535	0.545			
C	0.158	0.170	0.158	0.170			
D	TYP. 0.018		TYP. 0.018				
F	TYP. 0.060		TYP. 0.060				
G	0.09	0.11	0.09	0.11			
H	0.06	0.075	0.06	0.076			
J	0.009	0.015	0.009	0.015			
K	0.125	0.132	0.125	0.132			
L	0.600	0.625	0.600	0.620			
M	0'	10'	0'	10'			
N	0.008	—	0.008	—			

# PACKAGE DIMENSION

CER DIP

T-90-20

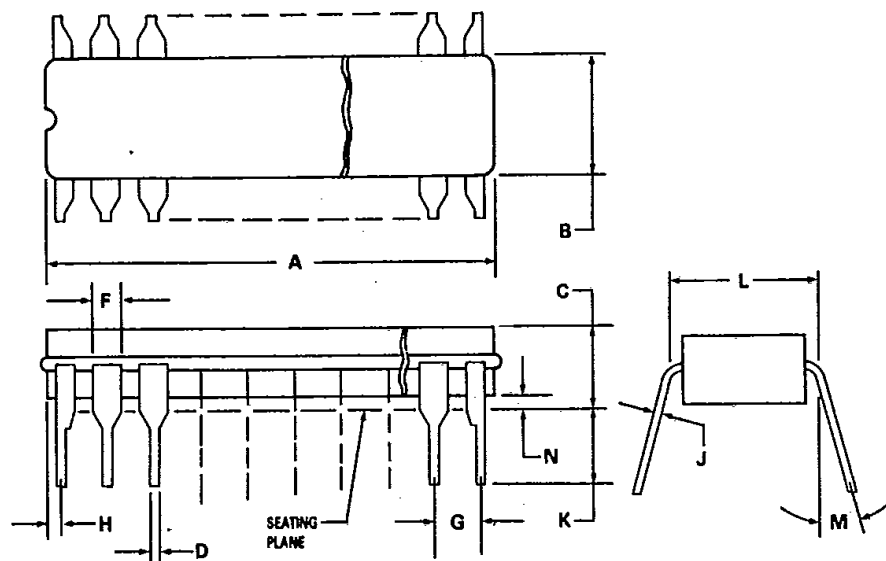

(UNIT : INCHES)

SYMBOL	16 PIN		20 PIN		24 PIN		28 PIN	
	MIN	MAX	MIN	MAX	MIN	MAX	MIN	MAX
A	0.753	0.785	0.940	0.985	1.240	1.290	1.440	1.485
B	0.272	0.294	0.265	0.306	0.514	0.526	0.514	0.598
C	0.165	0.200	0.165	0.200	0.165	0.200		0.225
D	0.015	0.021	0.015	0.021	0.015	0.021	0.015	0.023
F	0.055	0.065	0.055	0.065	0.055	0.065	0.055	0.065
G	0.09	0.11	0.09	0.11	0.09	0.11	0.09	0.11
H	0.012	0.060	0.012	0.060	0.040	0.098	0.040	0.098
J	0.008	0.012	0.008	0.012	0.008	0.012	0.008	0.012
K	0.125	0.20	0.125	0.20	0.125	0.20	0.125	0.20
L	0.29	0.32	0.29	0.32	0.590	0.620	0.590	0.620
M	0°	10°	0°	10°	0°	10°	0°	10°
N	0.02	0.06	0.02	0.07	0.02	0.07	0.02	0.07

# PACKAGE DIMENSION

SOP

T-90-20

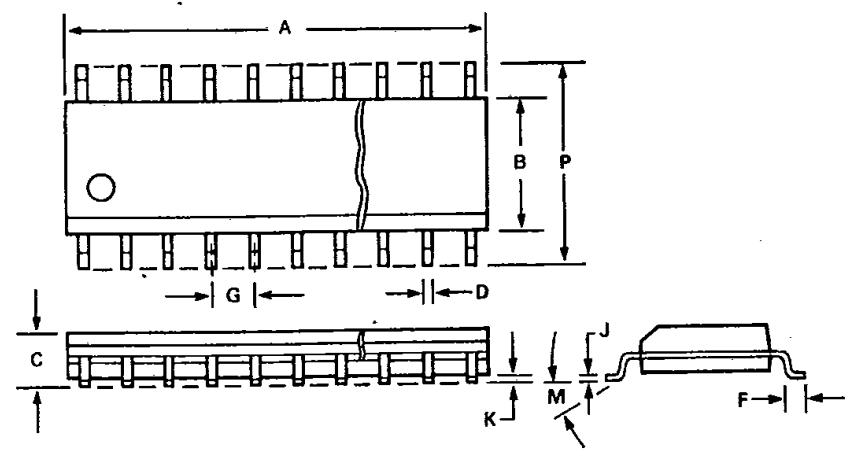

(UNIT : INCHES)

CODE NO. PIN SYMBOL	20 F		24 F		24 FW			
	20 PIN		24 PIN		24 PIN			
	MIN	MAX	MIN	MAX	MIN	MAX		
A	0.496	0.510	0.602	0.614	0.622	0.638		
B	0.292	0.299	0.292	0.299	TYP. 0.331			
C	0.097	0.104	0.097	0.104	—	0.098		
D	0.014	0.019	0.014	0.019	0.012	0.018		
F	0.018	0.035	0.018	0.035	TYP 0.039			
G	0.050 BSC		0.050 BSC		0.050 BSC			
J	0.010 BSC		0.010 BSC		0.010 BSC			
K	0.004	0.008	0.0055	0.0115	0.004			
P	0.400	0.410	0.400	0.410	0.453	0.477		
M	0°	8°	0°	8°	—	—		

CODE NO. PIN SYMBOL	28 F		28 FW			
	28 PIN		28 PIN			
	MIN	MAX	MIN	MAX		
A	0.703	0.712	0.720	0.750		
B	0.292	0.289	TYP. 0.331			
C	0.097	0.104		0.098		
D	0.014	0.019	0.012	0.018		
F	0.018	0.035	TYP. 0.039			
G	0.050 BSC		0.050 BSC			
J	0.010 BSC		0.010 BSC			
K	0.0055	0.0115	0.004	—		
P	0.400	0.410	0.453	0.477		
M	0°	8°	—	—		



# PACKAGE DIMENSION

SIDE BRAZED

T-90-20

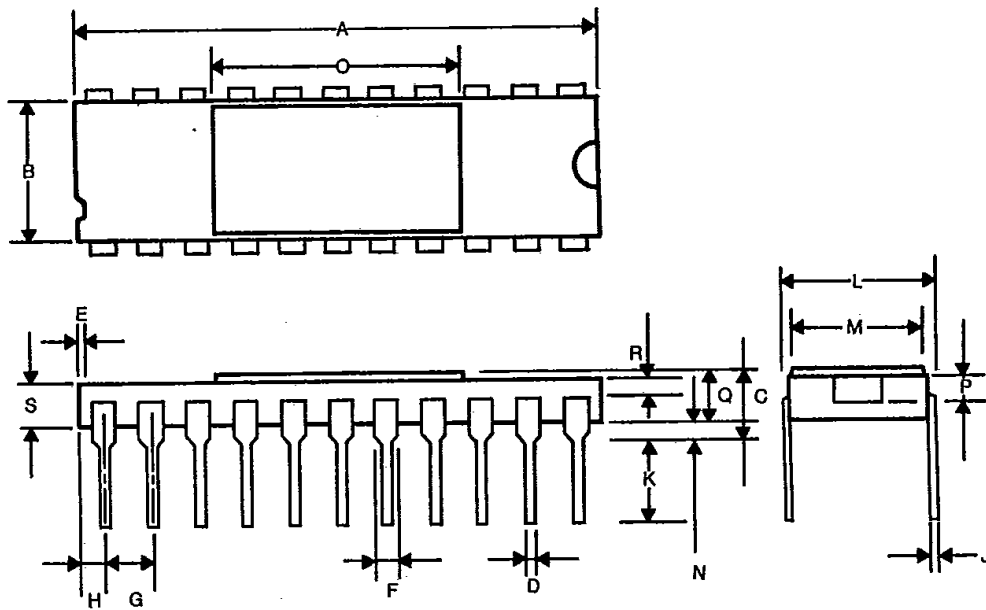

(UNIT: INCHES)

SYMBOL	22 PIN	
	MIN	MAX
A	1.088	1.112
B	0.281	0.298
C	—	0.160
D	0.016	0.020
E	0.004	—
F	TYP. 0.050	
G	0.09	0.105
H	0.035	0.065
J	0.009	0.011

SYMBOL	22 PIN	
	MIN	MAX
K	0.14	0.170
L	0.290	0.310
M	0.265	0.275
N	0.020	0.050
O	0.555	0.565
P	TYP. 0.050	
Q	0.092	0.122
R	0.005	—
S	0.08	—