

# Solid State

By Lou Garner

## CHIRP, JANGLE, WOOSH, BOOM!

**A** VERSATILE and unusual IC, virtually made-to-order for the experimenter and hobbyist, has been introduced by Texas Instruments, Inc., Box 84, Sherman, TX 75090. Designated the SN76477 complex sound generator, the new device is a monolithic IC combining both bipolar analog and I<sup>2</sup>L digital circuitry on a single silicon wafer. It includes basic circuit "blocks" which can be interconnected to produce an almost unlimited number of special sound effects ranging from a dog's bark or bird chirp to a gunshot or explosion. With the proper choice of external components, the SN76477 is capable of developing either familiar sounds such as a train whistle or futuristic sounds such as a "talking computer" or firing "phaser" ray gun. Offered in both standard 0.6-inch (1.5-cm) wide type N and the smaller 0.4-inch (1.0-cm) type NF 28-pin DIP's, the SN76477 can be powered by either a 5-volt regulated dc supply or well-filtered dc at 7.5 to 10.0 volts.

Not only is the SN76477 capable of producing a virtually unlimited variety of special sound effects, but the number of ways in which these may be used is limited only by the imagination and skill of the circuit designer and builder. In fact, a more experienced hobbyist might easily assemble a wide-range "Sound Effects Generator" by combining the SN76477 with a power amplifier, loudspeaker, and dc power supply. Such a project would also require multiple input and output jacks for the device terminals, potentiometers, various control switches, and a broad assortment of external components, selectable by means of appropriate rotary or toggle switches.

The functional block diagram of the new device is shown in Fig. 1. The SN76477 comprises a super-low-frequency (slf)

oscillator, a programmable logic circuit permitting a choice of inputs to a voltage-controlled oscillator (vco), a noise clock, noise generator, noise filter, logic circuits for both systems inhibit and envelope selection, a one-shot, an envelope generator and modulator, an output buffer amplifier, and voltage regulator. Most of the circuits can be controlled or programmed externally by suitable components or signals. Circuit inputs identified with circles are programmed by using different capacitor values, squares identify programming by means of various resistors, triangles via logic levels and diamonds by analog voltages. Device pinout is shown in Fig. 2.

The slf oscillator has a nominal range of 0.1 to 30 Hz, depending on the R and C values used for programming, but can be used to generate frequencies as high as 20,000 Hz. It supplies two output signals, a 50% duty-cycle square wave which is applied to the Mixer and a triangle wave which can be routed to either an external vco or, through the SLF SELECT logic circuit, to the on-chip vco which can supply a fixed or frequency-modulated output over an almost 10:1 frequency range. Its lowest frequency is established by the values of the external resistor and capacitor connected to pins 18 and 17, respectively. The vco's output signal also is coupled to the mixer. A noise clock generates clock pulses to control the noise generator which, in turn, develops pseudo-random white noise that is applied through a variable-bandwidth, low-pass noise filter to the mixer. Accepting input signals from one or more sources (slf, vco, noise filter), the mixer performs a logical AND function and delivers the resulting signal to the envelope generator and modulator circuit. The mixer output is estab-

Fig. 1. Functional block diagram of Texas Instruments' new SN76477 Complex Sound Generator integrated circuit.

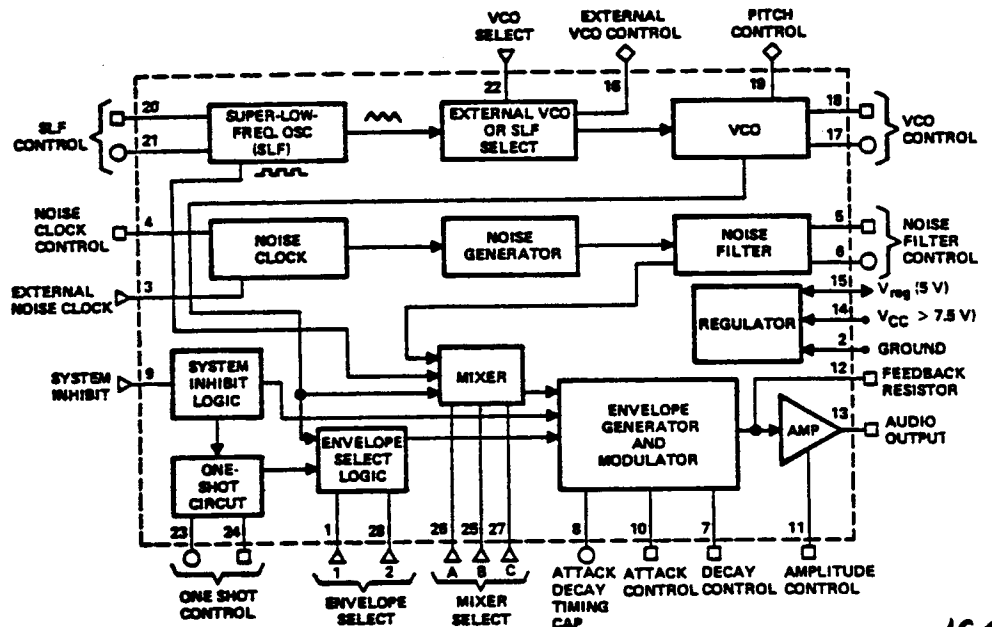

18c

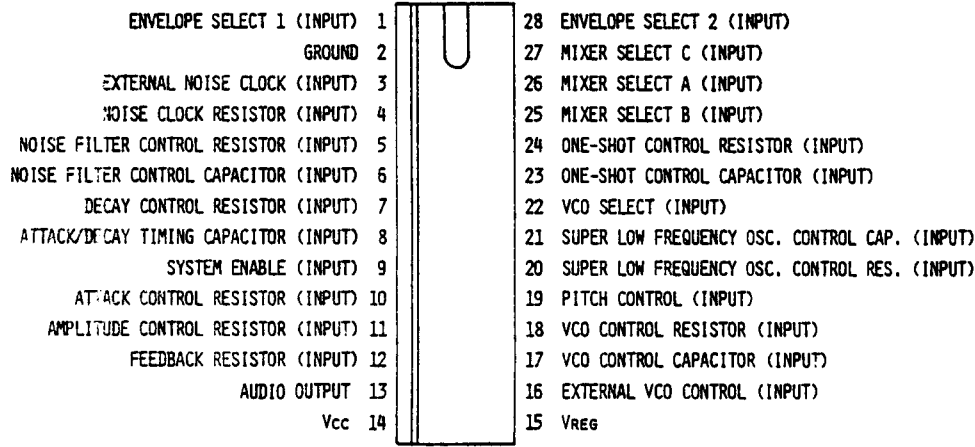

Fig. 2. Pin-out configuration and lead connections for the SN76477.

lished by the logic levels applied to its three SELECT terminals, pins 25, 26 and 27.

System inhibit logic circuit controls the system's output and also triggers a separate one-shot used to develop short-duration momentary sounds such as gunshots, bells or explosions. The duration of the one-shot's output is determined by the values of the control resistor and capacitor connected to pins 24 and 23, respectively, with the maximum period of approximately 10 seconds. The one-shot does not generate a sound signal itself, but is coupled through the envelope select logic circuit to the envelope generator and modulator, which provides an envelope for the signals from the mixer.

The envelope select logic circuit establishes the overall shape of the envelope which amplitude modulates the combined signal obtained from the mixer. Depending on the logic signals applied to ENVELOPE SELECT control pins 1 and 28, one of several operating modes can be selected, including vco, mixer only, one-shot, and vco with alternating cycles. The final shaping of the generated signal is performed by the envelope generator and modulator circuit, where the slf, vco, and filtered noise signals from the mixer are controlled by the system inhibit logic and modulated with the envelope established by the envelope select logic. This circuit also acts to modify the resulting signal's attack (rise time) and decay (fall time) characteristics.

Developing a maximum 2.5 volts, peak-to-peak, the output amplifier buffers the signal so that it can be applied to an external modulator or power amplifier. The buffer has a low output impedance. Finally, the regulator is designed to operate from either of two power sources. If available, 5 volts regulated dc can be applied to pin 15 (V<sub>REG</sub>). Alternatively, 7.5 to 10

volts unregulated dc can be applied to pin 14 (V<sub>CC</sub>), in which case the on-chip regulator will furnish a 5 V regulated output at up to 10 mA to power other circuits.

In summary, the SN76477 generates complex audio signal waveforms by combining the outputs of a low frequency oscillator, variable frequency (voltage controlled) oscillator, and noise source, modulating the resulting composite signal with a selected envelope and, finally, adjusting the signal's attack and decay periods. At each stage, the process can be controlled at the programming inputs of the signal modification and generation circuits, using control voltages, logic levels, or different resistor and capacitor values.

Representative signal waveforms developed during the process are illustrated in Fig. 3. The mixer output in the example shown in Fig. 3A is a variable-frequency signal containing filtered noise elements. This is modulated with a pulse envelope obtained from the one-shot and then shaped to form different types of sounds by altering the signal's attack and decay. In the second example (Fig. 3B), the mixer output is modulated by a repetitive pulse derived from the vco.

Different sounds are developed by varying the attack or decay, or both. The attack and decay can be modified by connecting different capacitor values to pin 8 and different resistor values to pins 10 and 7 which control the attack and decay, respectively.

Practical circuits featuring the SN76477 are illustrated in the figures. These were selected from among many circuits described in TI's data sheets. All feature a simple but effective audio amplifier to provide a low-level loudspeaker output and are designed for operation on a standard 9-volt transistor battery. At those points in the circuits where 5 V is required, it

Fig. 3. Complex signal waveforms showing different attack and decay characteristics with (A) one-shot and (B) voltage-controlled oscillator modulation envelopes.

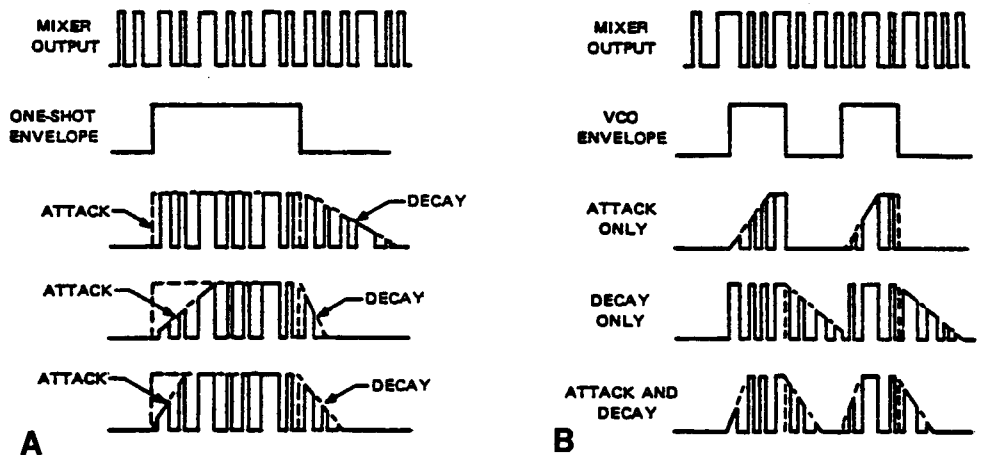

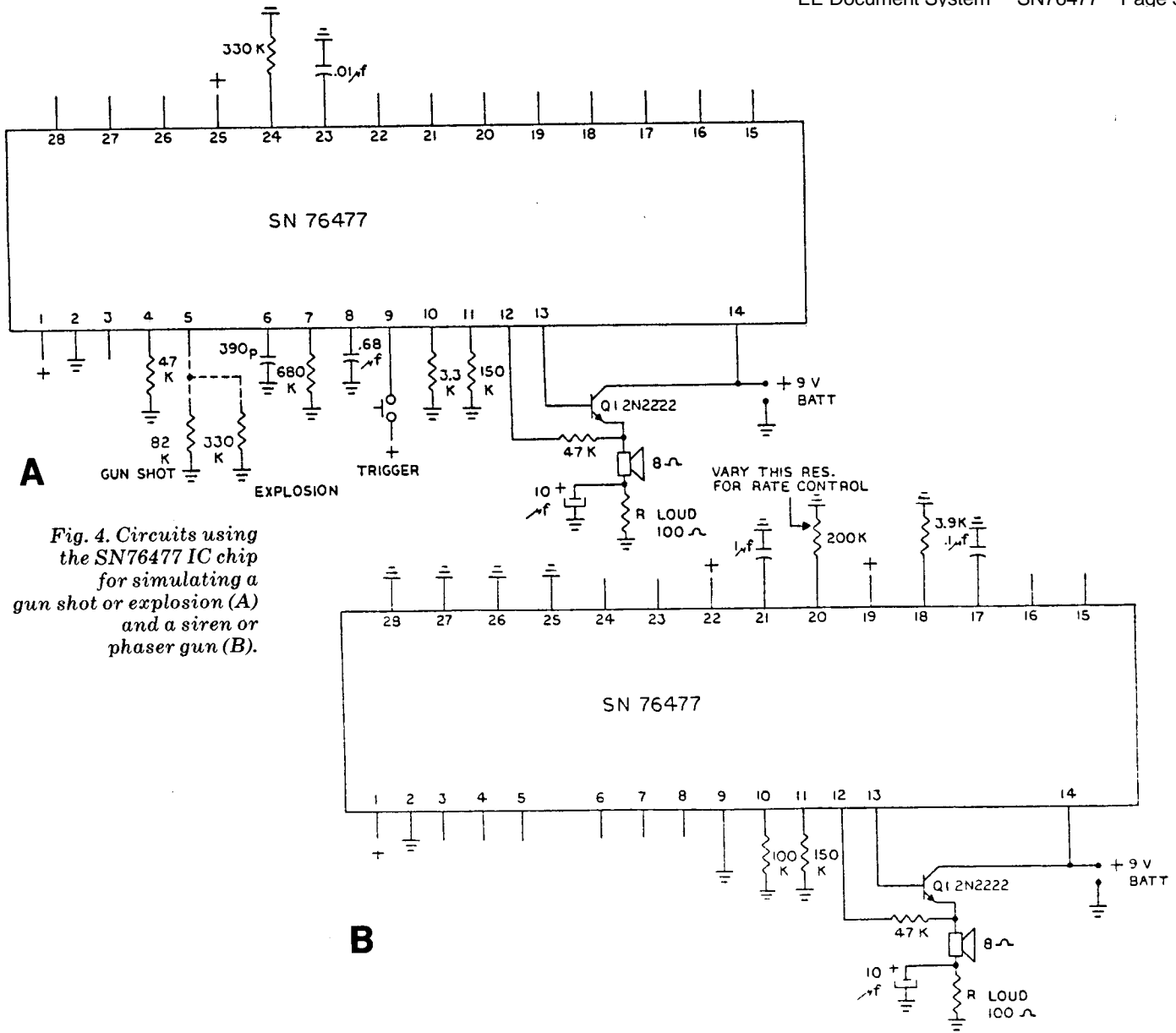

**Fig. 4. Circuits using the SN76477 IC chip for simulating a gun shot or explosion (A) and a siren or phaser gun (B).**

can be derived from pin 15 of the IC. All can be assembled using standard, readily available components. Except where potentiometers are specified, all resistors are either 1/4- or 1/2-watt components. Small capacitors can be ceramic, plastic film, or tubular paper units; larger capacitances are 15-volt electrolytics.

Neither layout nor lead dress are critical in any of the circuits, which can be duplicated using a solderless breadboard, perforated or printed circuit board. The usual precautions should be observed when soldering to avoid overheating the semiconductors, and all polarities must be observed.

When duplicating a normally loud sound such as a gunshot or explosion, it will be necessary to couple the circuit to a high-power audio amplifier driving a large loudspeaker. However, a 4-to-6-inch (10.2-to-15.3-cm) loudspeaker and the push-pull amplifier shown in the schematics should be adequate for most applications.

Designed to simulate the sounds of either a gunshot or explosion, the circuit shown in Fig. 4A is triggered by applying a 5-volt pulse through a momentary-contact, normally open pushbutton switch to the system inhibit logic and one-shot cir-

cuits (pin 9). The 5-volt dc level required here as well as for the envelope select logic (pin 1) and mixer select (pin 25) is obtained from the IC's V<sub>REG</sub> output (pin 15). Different resistor values are used to program the noise filter circuit (pin 5) to simulate the two sounds, (82,000 ohms for a gunshot and 330,000 ohms for an explosion).

Several different sounds can be simulated by the circuit shown in Fig. 4B, including a siren, space war, or "phaser" gun, depending on the adjustment of the 200,000-ohm RATE CONTROL potentiometer. For increased realism, the IC's one-shot (pins 9, 23, 24) and decay (pins 8, 7) functions can be implemented. As before, +5 volts dc needed for pins 1, 19, 22 is obtained from V<sub>REG</sub> (pin 15).

Circuits for simulating the sounds of a racing car motor or crash and a chugging steam engine or reciprocating airplane engine are shown in Fig. 5A and 5B, respectively. In the first circuit, the racing car motor's rev rate is adjustable by means of a 100,000-ohm potentiometer which varies the dc voltage applied to the external vco control input (pin 16). The maximum and minimum rev rates are set by fixed resistors in series with the potentiometer. A crashing sound is initiate

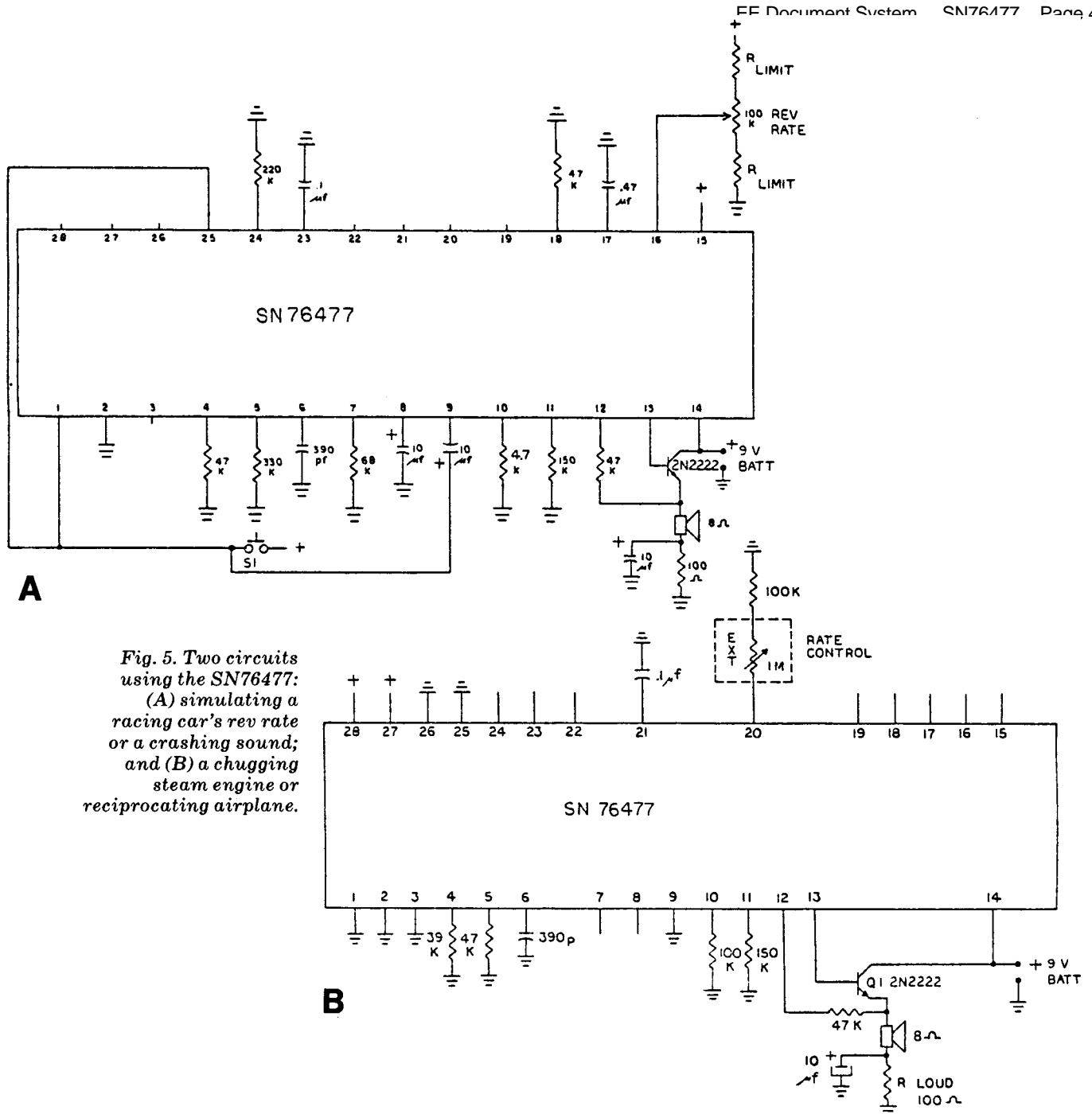

Fig. 5. Two circuits using the SN76477: (A) simulating a racing car's rev rate or a crashing sound; and (B) a chugging steam engine or reciprocating airplane.

depressing a spst normally open pushbutton switch, which applies a voltage pulse through a 10-μF capacitor to the system inhibit logic and one-shot circuits (pin 9), simultaneously changing the envelope select (pin 1) and mixer select (pin 25) settings.

In the second circuit, the self oscillator frequency is controlled by a 1-megohm potentiometer connected to one of its programming input (pin 20). As this RATE CONTROL is adjusted from a very low to a moderately low frequency, the generated sound is like that of a steam engine gradually increasing in speed. At higher frequencies, the sound approximates that of a propeller-driven airplane.

From a technical viewpoint, there's virtually no limit to the number and types of sounds that can be generated using one, two, three or more SN76477 IC's in conjunction with multiplexing and external programming networks. By using pro-

grammable analog switches to select outputs from different units, for example, a clever experimenter easily could create circuits to generate background jungle noises, night sounds, complete battlefield or eerie haunted-house sounds, or even musical selections interspersed with unusual sound effects. In commercial and industrial alarm applications, different sounds could be used to identify various danger conditions, such as illegal entry, fire, basement flooding, or power failure. The IC's are available through TI franchised dealers and are relatively inexpensive. The rest is up to your imagination!

**Reader's Circuit.** Alan Peter Allegra (218 11th Ave., Bethlehem, PA 18018) was intrigued with J. Fortuna's "Digitart" project in our column of April 1977. One of his friends, Frank Resul, had designed a "combination lock" digital ignition switch for his '75 VW sometime earlier.