

Description

The ITM1010 is an integrated receiver front-end IC for 800 MHz Cellular CDMA and 450MHz CDMA450 mobile phones. The device has an LNA and a down-converter on a single die. Its low noise amplifier and mixer have high linearity and high gain. The LNA has two-step gain control scheme, increasing dynamic range while saving current. Gain, noise figure, and linearity of the mixer can be easily adjusted using an external inductor.

The ITM1010 is fabricated on an advanced SiGe BiCMOS process which facilitates low-noise, low-power, high-frequency analog circuits along with CMOS control function. The ITM1010 uses tiny 12-pin 2.5mm x 2.5mm Leadless Plastic Chip Carrier (LPCC) package, which is the smallest CDMA receiver chip in the world.

Applications

- Cellular CDMA/CDMA450 Mobile Phone (@ IS-95A/B/C, CDMA2000, CDMA20001X)
- 450 MHz CDMA Receiver
- 800 MHz CDMA and TDMA Receivers
- Portable Radio Handset and Equipments

Features

- World's smallest 2.5 mm x 2.5 mm CDMA receiver chip
- Operating frequency:
 - CDMA Cellular : 869 ~ 894 MHz
 - CDMA 450 : 460 ~ 470 MHz
- High linearity and high gain
- Two step LNA gain control
- 16 dB Gain, 1.2 dB NF, 9.5 dBm IIP3 LNA
- Adjustable Gain, NF, IIP3 of mixer using an external inductor
- All pins are ESD-protected
- Tiny 12-pin LPCC package (2.5mm ´ 2.5mm ´ 0.9mm)

Functional Block Diagram

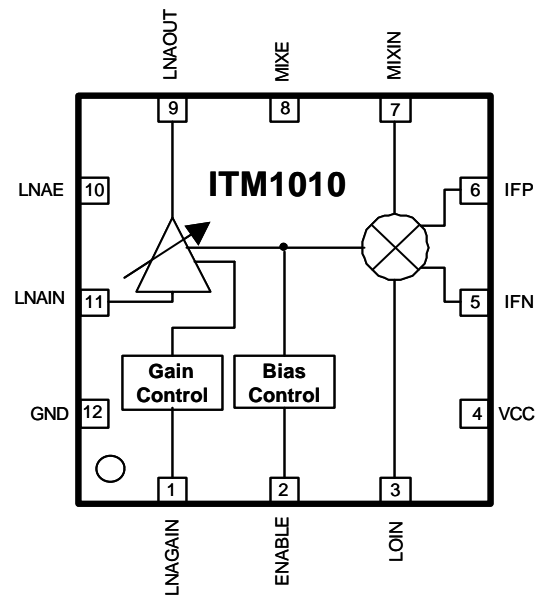

Ordering Information

Part	Package
ITM1010	12-pin 2.5mmx2.5mm LPCC
ITM1010TR	ITM1010 Tape and Reel
ITM1010EV	ITM1010 Evaluation Board (800MHz)
ITM1010EV45	ITM1010 Evaluation Board (450MHz)

Integrant Technologies Inc.

D-206, Bundang Technopark 151, Yatab-dong, Bundang-Gu, Seongnam-Si, Kyeongki-do 463-760, KOREA

Tel : 82-31-719-4500, Fax. : 82-31-719-4506

For pricing, delivery, and ordering information, please contact sales@integrant.biz or visit www.integrant.biz.

1. Operating Conditions

1-1 Absolute Maximum Ratings

The ratings described below are stress-only, and the device's performance might be degraded and/or permanent damage might be caused by the stresses applied beyond these ratings.

Table 1-1 Absolute Maximum Ratings

Parameter	Symbol	Min	Max	Unit
Supply Voltage	V _{CC}	-0.5	3.6	V
Digital Input Voltage to Ground	V _D	-0.3	V _{CC} +0.3	V
Input Power Level	P _{Imax}		6	dBm
Storage Temperature	T _S	-40	150	°C
Junction Temperature	T _J		150	°C
Lead Temperature (Soldering, 10sec)	T _L		240	°C

1-2 Recommended Operating Conditions

All device performance of ITM1010 is guaranteed under these Recommended Operating Conditions.

Table 1-2 Recommended Operation Conditions

Parameter	Symbol	Min	Max	Unit
Supply Voltage	V _{CC}	2.7	3.15	V
Operating Temperature	T _A	-40	85	°C
Logic High Level Input Voltage	V _{IH}	1.8		V
Logic Low Level Input Voltage	V _{IL}		0.4	V

1-3 Typical Current Consumption

Table 1-3 Typical Current Consumption

Parameter	Typical	Unit
Cellular CDMA	High Gain	28
	Low Gain	19
Power Down Current	< 1	μA

Note: Typical current consumption is measured at 25° C and V_{CC}=2.85V

1-4 Electrical Mode

Table 1-4 Operation Mode Control Table

ENA	LNA_GAIN	Operation Mode
0	X	Full Power Down
1	0	LNA low gain
1	1	LNA high gain

2. RF Specifications

2-1 CDMA LNA

Table 2-1 CDMA LNA RF Specifications¹

Specification	Min	Typ	Max	Unit	Comments
RF Frequency Range	869		894	MHz	
Input VSWR			2:1		
Output VSWR			2:1		
High Gain Mode					
Gain	15	16		dB	
Noise Figure		1.2	1.5	dB	
Input IP3	8.5	9.5		dBm	
Low Gain Mode					
Gain		-3.5		dB	
Noise Figure		4.8		dB	
Input IP3		23		dBm	

2-2 CDMA Downconverter

Table 2-2 CDMA Downconverter Specifications¹

Specification	Min	Typ	Max	Unit	Comments
RF Frequency Range	869		894	MHz	
IF Frequency Range	50	85.38	300	MHz	
Gain	8.5	9.5		dB	
Noise Figure		9.5	10.5	dB	
IIP3	8.7	10		dBm	
Output Impedance		1000		Ohm	
LO Power		-7		dBm	
Input VSWR			2:1		
Output VSWR			2:1		
LO to RF Isolation	25			dB	
LO to IF Isolation	35			dB	
RF to LO Isolation	26			dB	

2-3 CDMA Cascaded Performance

Table 2-3 CDMA Cascaded Specifications^{1,2}

Specification	Min	Typ	Max	Unit	Comments
RF Frequency Range	869		894	MHz	
IF Frequency Range	50	85.38	300	MHz	
Gain		23.5		dB	
Noise Figure		2.15		dB	
IIP3		-4.2		dBm	
IF Output Impedance		1000		Ohm	
LO Level		-7		dBm	
Input VSWR			2:1		
Output VSWR			2:1		

Notes

1. The measurement condition is $T_A=25^\circ\text{C}$ and $V_{CC}=3\text{V}$ with mixer emitter degeneration inductor (L4 in Fig. 4-1) of 8.2 nH (default value).
2. Filter noise figure of 2.0dB is used for calculation of cascaded performance.

2-4 CDMA450 LNA

Table 2-4 450MHz CDMA LNA RF Specifications³

Specification	Min	Typ	Max	Unit	Comments
RF Frequency Range	400		500	MHz	
Input VSWR			2:1		
Output VSWR			2:1		
High Gain Mode					
Gain	15.5	16.5		dB	
Noise Figure		1.6	1.9	dB	
Input IP3	8.5	9.5		dBm	
Low Gain Mode					
Gain		-3.5		dB	
Noise Figure		3.3		dB	
Input IP3		25		dBm	

2-5 CDMA450 Downconverter

Table 2-5 450MHz CDMA Downconverter Specifications³

Specification	Min	Typ	Max	Unit	Comments
RF Frequency Range	460		470	MHz	
IF Frequency Range	50	85.38	300	MHz	
Gain	9.5	10.5		dB	
Noise Figure		8.5	10	dB	
IIP3	5.7	7		dBm	
Output Impedance		1000		Ohm	
LO Power		-10		dBm	
Input VSWR			2:1		
Output VSWR			2:1		
LO to RF Isolation	25			dB	
LO to IF Isolation	35			dB	
RF to LO Isolation	26			dB	

2-6 CDMA450 Cascaded Performance

Table 2-6 450MHz CDMA Cascaded Specifications^{3,4}

Specification	Min	Typ	Max	Unit	Comments
RF Frequency Range	460		470	MHz	
IF Frequency Range	50	85.38	300	MHz	
Gain		25		dB	
Noise Figure		2.2		dB	
IIP3		-7.6		dBm	
IF Output Impedance		1000		Ohm	
LO Level		-10		dBm	
Input VSWR			2:1		
Output VSWR			2:1		

Notes

3. The measurement condition is $T_A=25^\circ\text{C}$ and $V_{CC}=2.85\text{V}$ with mixer emitter degeneration inductor (L4 in Fig. 4-2) of 18 nH (default value).
4. Filter noise figure of 2.0dB is used for calculation of cascaded performance.

3. Typical Operating Characteristics

CDMA450

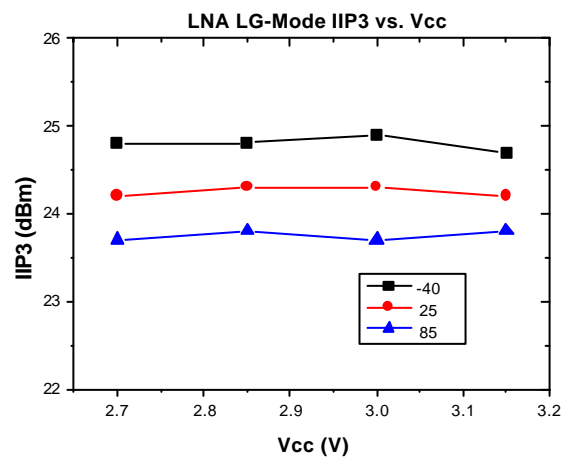
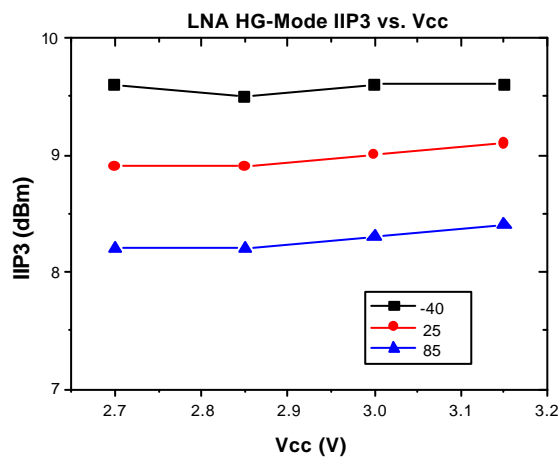
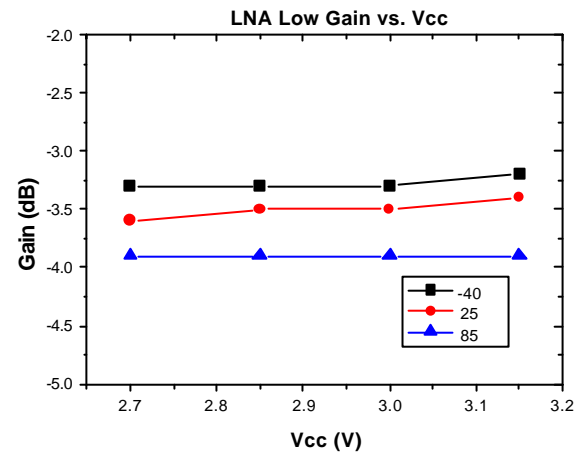
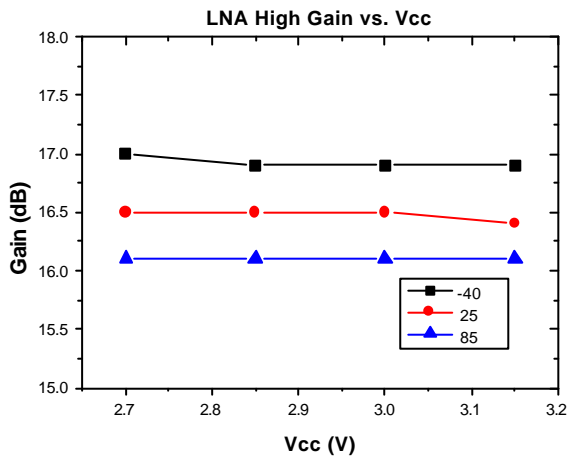
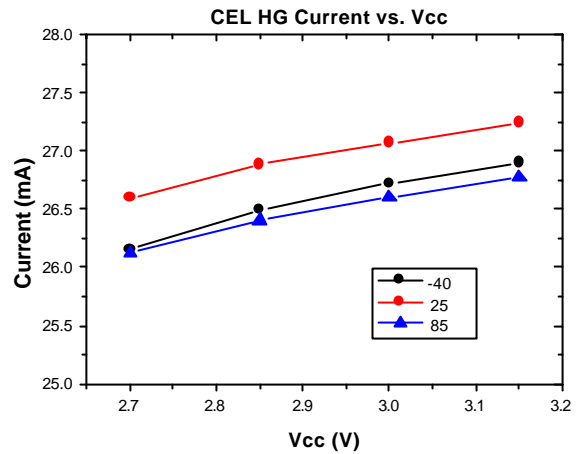
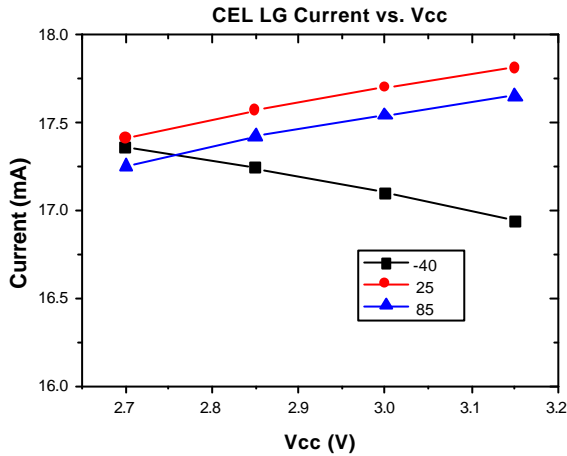

3. Typical Operating Characteristics(Cont' d)

CDMA450

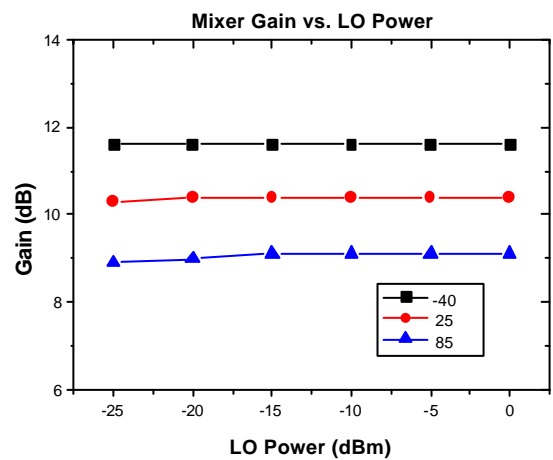
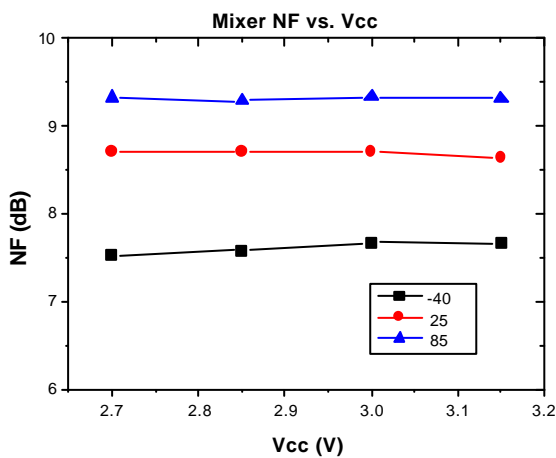
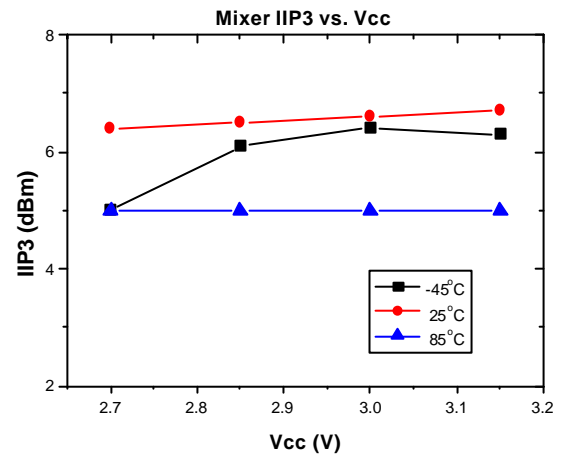
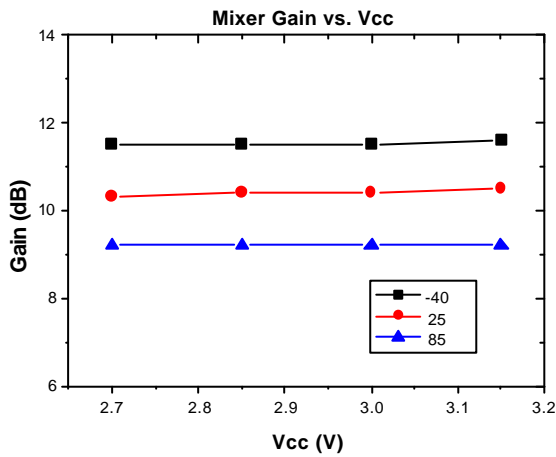
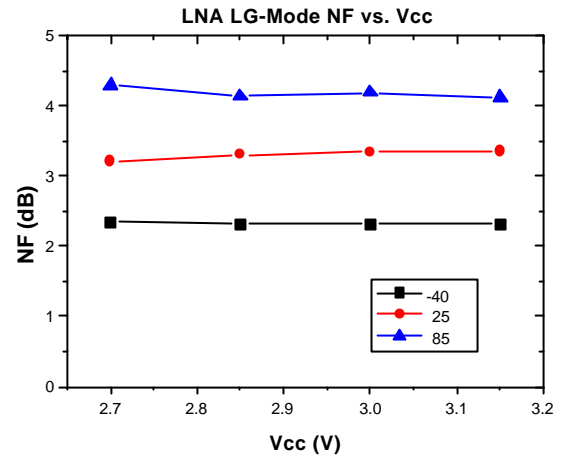
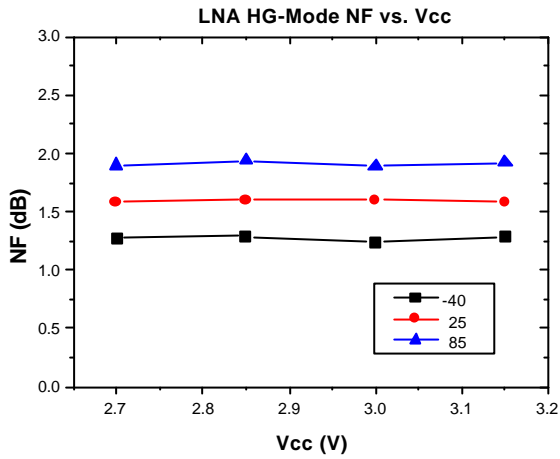

3. Typical Operating Characteristics(Cont' d)

CDMA450

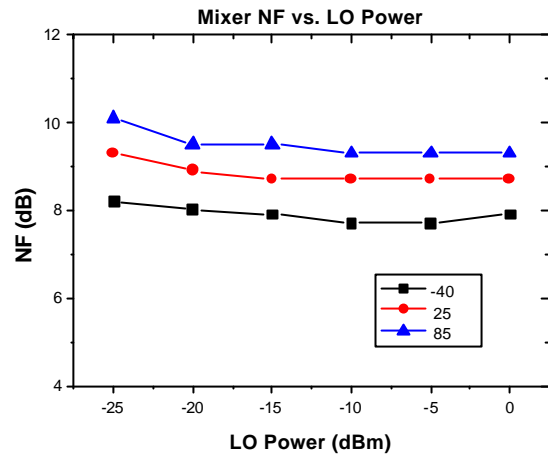
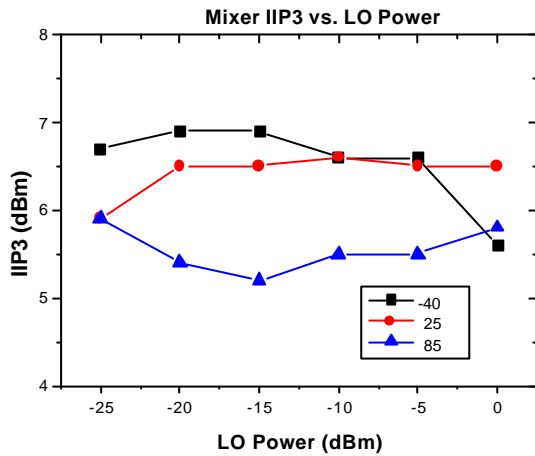

4. PIN Assignment

Table 4-1 PIN Assignment Table

PIN	Symbol	Description
1	LNA_GAIN	LNA Gain Control Pin. With LNA_GAIN=HIGH, LNA operates at high-gain mode, and with LNA_GAIN=LOW LNA operates at low-gain mode.
2	ENA	Enable Pin. If ENA is LOW, the device operates at full power-down mode. If ENA is HIGH the device operates at active mode.
3	LO_IN	Mixer LO input
4	VCC	Power supply voltage
5	IFN	Negative mixer output (open collector)
6	IFP	Positive mixer output (open collector)
7	MIX_IN	Mixer RF input
8	MIX_E	Mixer emitter degeneration
9	LNA_OUT	LNA output (open collector). Requires external matching network.
10	LNA_E	LNA emitter degeneration
11	LNA_IN	LNA RF input. Requires external matching network.
12	GND	Ground

5. Evaluation Board Schematic

5-1. CDMA Cellular Band(869 ~ 894 MHz)

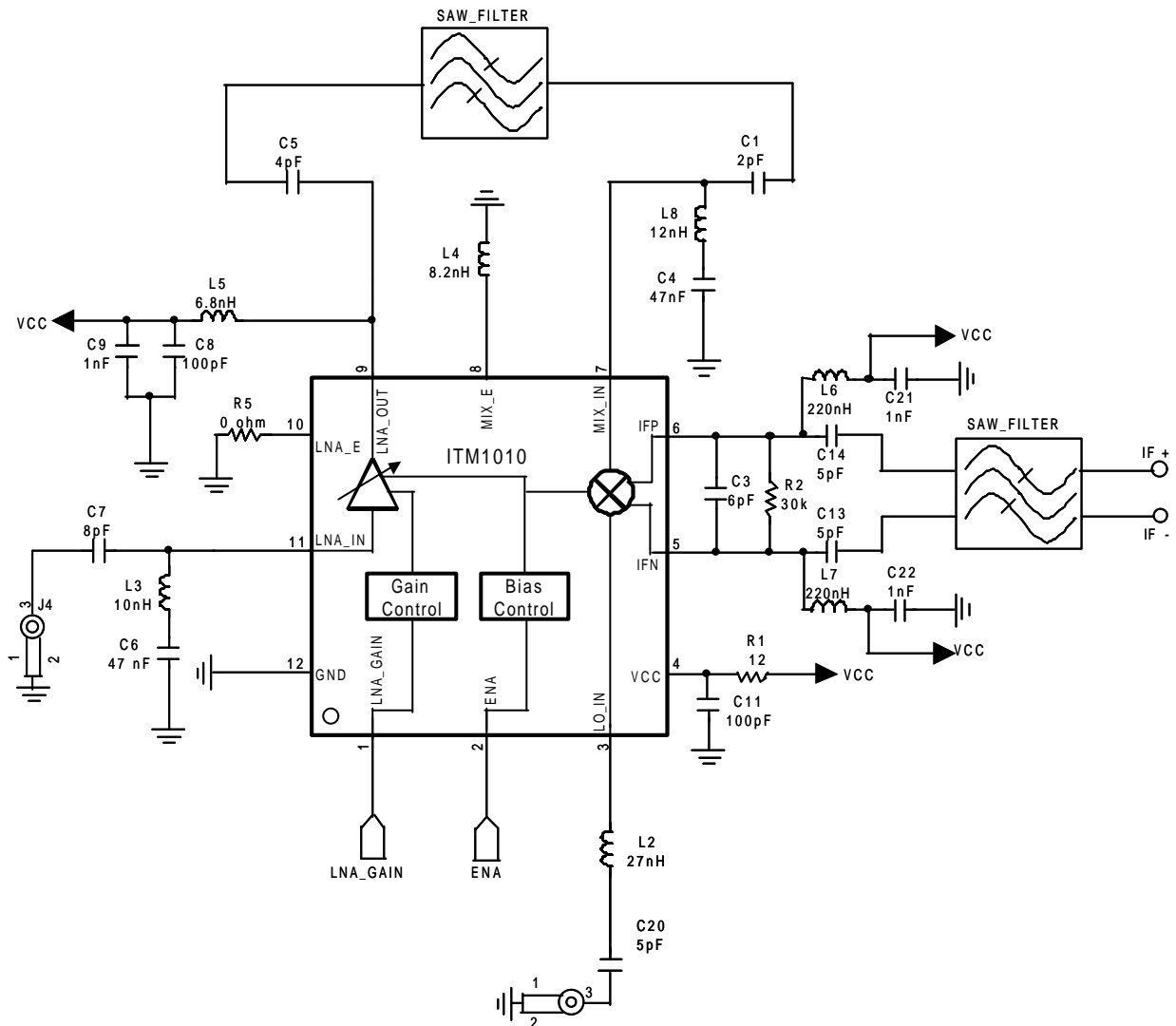

Fig. 5-1 Evaluation Board Schematic for CDMA Cellular Application

5-2. CDMA450 Band(460 ~ 470 MHz)

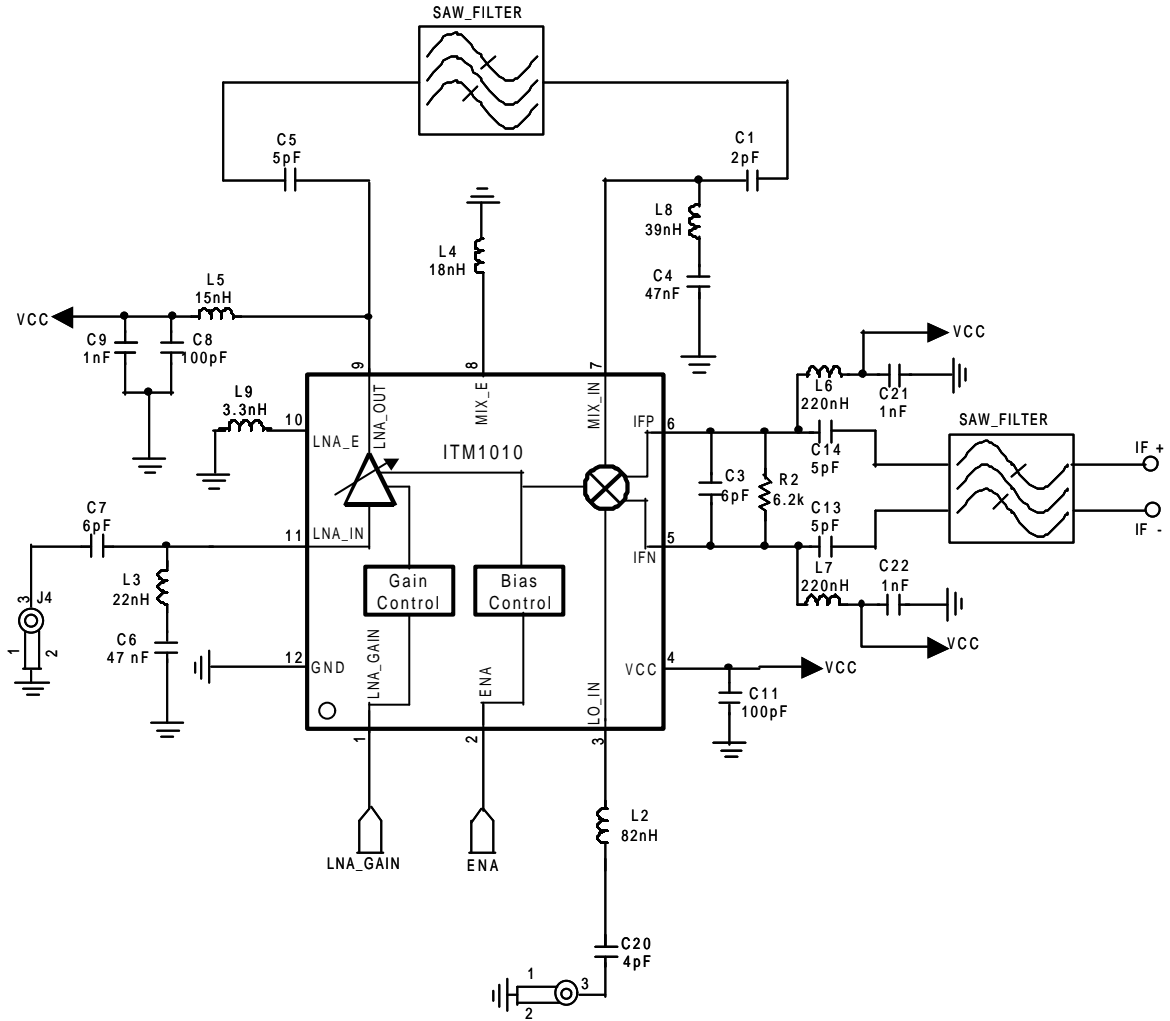

Fig. 5-2 Evaluation Board Schematic for CDMA450 Application

6. External Components

6-1. CDMA cellular application

The external components below are used in the ITM1010 Evaluation Board, as shown in Fig. 5-1, for 800MHz CDMA cellular application.

Table 5-1 External Component Information for CDMA cellular application

Component	Model	Type	Part Number	Comment
C1	Murata, 2 pF	0402		
C3	Murata, 6 pF	0402		
C4	Murata, 47 nF	0402		
C5	Murata, 4 pF	0402		
C6	Murata, 47 nF	0402		
C7	Murata, 8 pF	0402		
C8	Murata, 100 pF	0402		
C9	Murata, 1 nF	0402		
C11	Murata, 100 pF	0402		
C13	Murata, 5 pF	0402		
C14	Murata, 5 pF	0402		
C20	Murata, 100 pF	0402		
C21	Murata, 1 nF	0402		
C22	Murata, 1 nF	0402		
L2	Toko, 27 nH	0402		
L3	Toko, 10 nH	0402		
L4	Toko, 6.8 nH	0402		
L5	Toko, 6.8 nH	0402		
L6	Coil Craft, 220 nH	0603		
L7	Coil Craft, 220 nH	0603		
L8	Toko, 12 nH	0402		
R1	12 Ω	0402		
R2	6.8 k Ω	0402		
R5	0 Ω	0402		

6-2. CDMA450 application

The external components below are used in the ITM1010 Evaluation Board, as shown in Fig. 5-2, for 450MHz CDMA450 application.

Table 5-2 External Component Information for CDMA450 application

Component	Model	Type	Part Number	Comment
C1	Murata, 2 pF	0402		
C3	Murata, 6 pF	0402		
C4	Murata, 47 nF	0402		
C5	Murata, 5 pF	0402		
C6	Murata, 47 nF	0402		
C7	Murata, 6 pF	0402		
C8	Murata, 100 pF	0402		
C9	Murata, 1 nF	0402		
C11	Murata, 100 pF	0402		
C13	Murata, 5 pF	0402		
C14	Murata, 5 pF	0402		
C20	Murata, 100 pF	0402		
C21	Murata, 1 nF	0402		
C22	Murata, 1 nF	0402		
L2	Toko, 82 nH	0402		
L3	Toko, 22 nH	0402		
L4	Toko, 18 nH	0402		
L5	Toko, 15 nH	0402		
L6	Toko, 220 nH	0603		
L7	Toko, 220 nH	0603		
L8	Toko, 39 nH	0402		
L9	Toko, 3.3 nH	0402		
R2	6.8 kΩ	0402		

7. Package Information

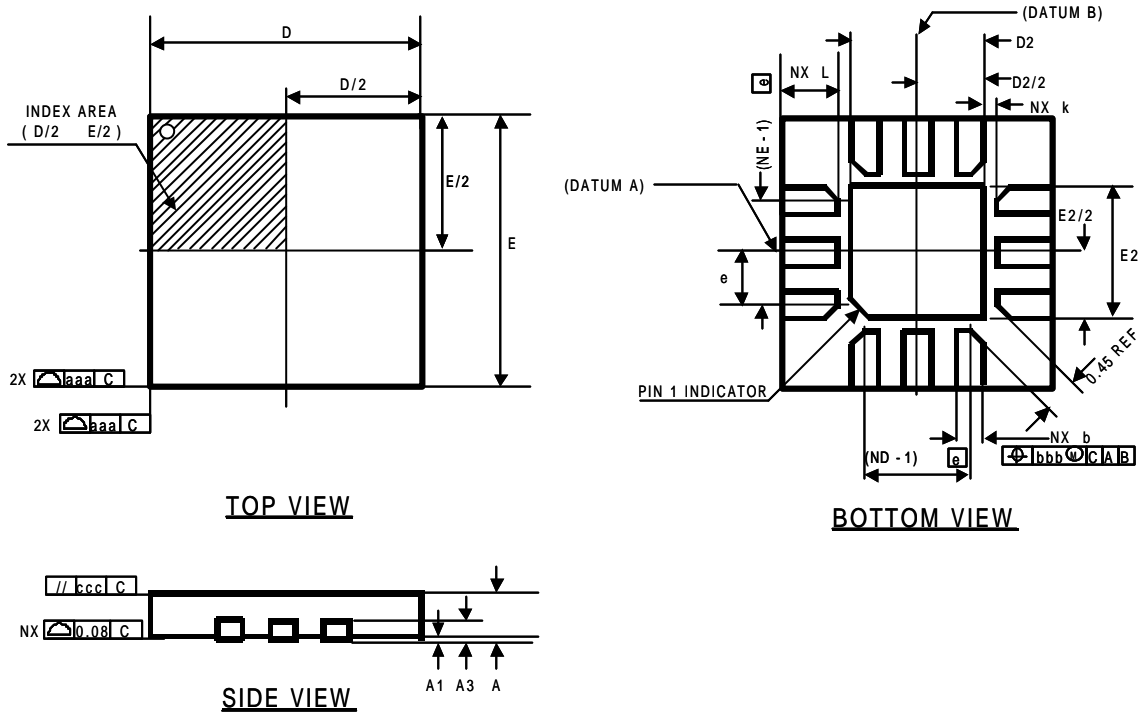

PACKAGE	12L 2.5 2.5 -0.5 PITCH		
REF	MIN	NOM	MAX
A	0.80	0.90	1.00
b	0.225	0.25	0.275
D	2.40	2.50	2.60
D2	1.20	1.30	1.40
E	2.40	2.50	2.60
E2	1.20	1.30	1.40
e	0.50 BSC		
L	0.35	0.40	0.45
N	12		
ND	3		
NE	3		

PACKAGE	COMMON DIMENSIONS		
REF	MIN	NOM	MAX
A1	0	0.02	0.05
A3		0.25 REF	
K	0.20	-	-
TOLERANCES OF FORM POSITION			
aaa		0.15	
bbb		0.10	
ccc		0.10	

1. Dimensioning and tolerancing confirm to ASME Y14-1994
2. N is the total number of solder pads
3. All dimensions are in millimeter. Angles are in degrees.

Fig. 7-1 Package Information

8. Layout Guidelines

The guidelines listed below help the users to achieve the optimum performance of ITM1010 when drawing their layout. These guidelines are recommended.

- Keep RF signal lines as short as possible to minimize unnecessary losses and radiation.
- For the best noise performance of LNA, keep the pad-to-pad distance in LNA input line as short as possible. The minimum distance is recommended. Also, use high Q components in LNA input-matching circuit.
- The 0 ohm resistor between pin 10(LNA_E) and ground is used as a degeneration inductor of the LNA for 800MHz application. This component should not be eliminated. It can also be replaced with chip inductors to increase IP3 of LNA at the cost of smaller gain and higher noise figure.
- At the mixer outputs (pin 5 and pin 6), keep the differential signal lines of the same length to ensure signal balance. Symmetrical PCB layout is recommended.
- High value (47nF) chip capacitors in the evaluation board (Fig. 4-1) are used for optimum IP3 performance of ITM1010. Do not replace these capacitors with smaller value capacitors.
- For various duplexer and RF SAW filters, sensitivity and IMD performance can be optimized by tuning R5, L4 and R2 in Fig. 4-1.
- Parasitic impedances at pins 8 (MIX_E) and 10 (LNA_E) might affect RF performance significantly because these pins are used as degeneration. Short PCB lines are recommended for these two pins.
- Generally, high LO power is preferable for high gain/IIP3 and low noise figure of the mixer.

9. Recommended PCB Land Pattern

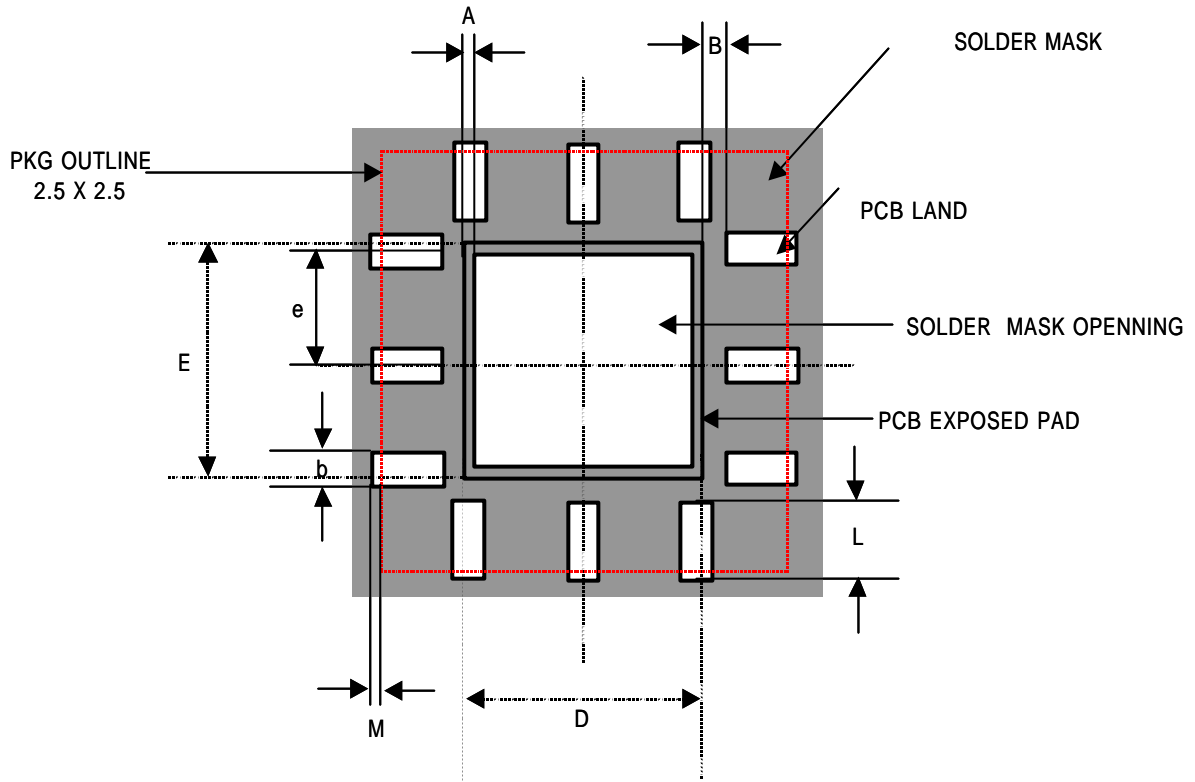

[Unit: mm]

REF	MIN	NOM	MAX
A	0.0635		
B	0.2		
D	1.20	1.30	1.40
E	1.20	1.30	1.40
b	0.225	0.25	0.275
e	0.50 BSC		
L	0.45	0.5	0.55
N	12		
M	0.1		

1. N is the total number of solder pads.
2. The exposed pad must be connected to the ground through the via holes and the via holes must be as many as possible.
3. A= Clearance from PCB thermal pad to solder mask opening.
4. B= Clearance from edge of PCB thermal pad to PCB land.
5. L= PCB land length.
6. b= PCB land width.
7. D,E= Ground thermal pad size
8. M= (PCB land length) – (Package solder pad length)

10. Tape and Reel Information

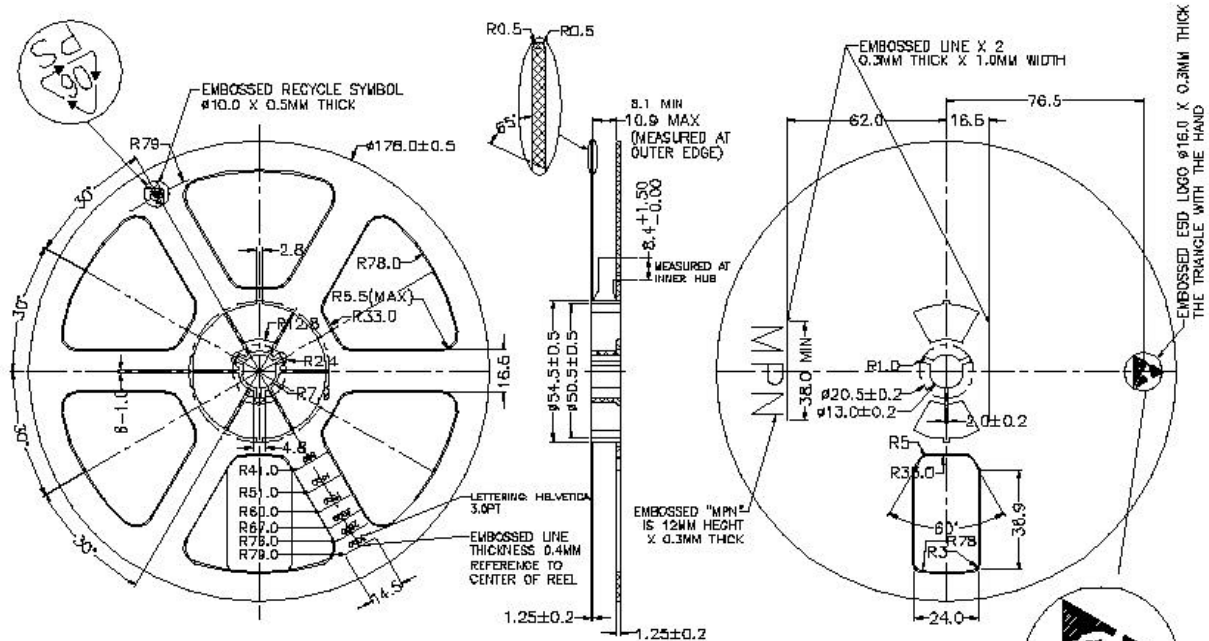

- NOTES:
1. MATERIAL : POLYSTYRENE (BLUE)
 2. ANTISTATIC COATED
 3. ALL DIMENSIONS ARE IN MM
 4. ESD SURFACE RESISTIVITY - 10^7 TO 10^9 OHMS/SQ
 5. GENERAL TOLERANCE : ± 0.5 , ± 0.25 ANGLE: ± 0.5
 6. P/N: P403D
- UNLESS OTHERWISE SPECIFIED

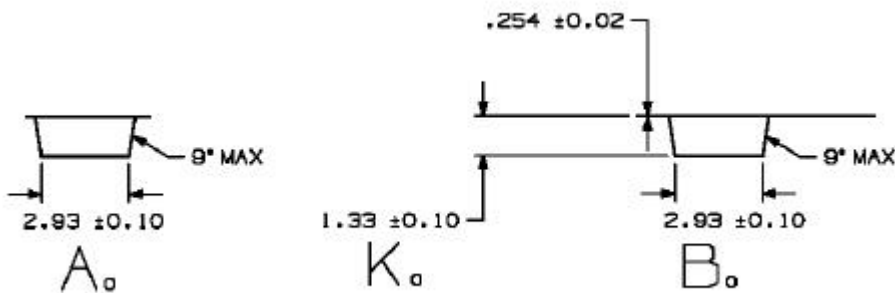
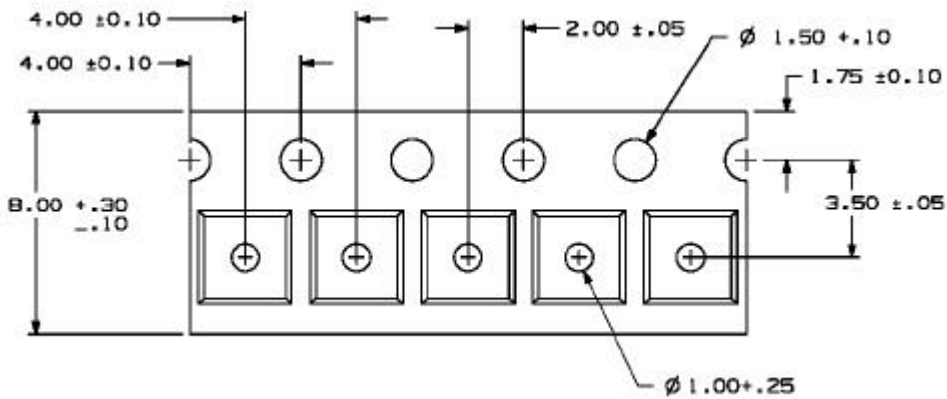

11. Device Marking

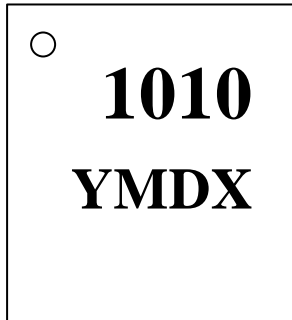

○	PIN 1 Identifier
1010	Product Code Name
YMDX	Lot Code

Note : The device marking can be subjected to change without any notice.