

Features

- Operating voltage
 - HT48R50-1: 3.0V~5.2V
 - HT48R50-2: 2.4V~4.0V
- 32 bidirectional I/O lines
- One interrupt input
- One 8-bit and one 16-bit programmable timer/event counters with overflow interrupts
- On-chip crystal and RC oscillator
- Watchdog timer
- 4K × 15 program memory PROM
- 1 × 14 option memory PROM
- 184 × 8 data memory RAM
- Halt function and wake-up feature reduce power consumption
- Up to 1μs instruction cycle with 4MHz system clock at V_{DD}=5V
- Four-level subroutine nesting
- All instructions in one or two machine cycles
- 15-bit table read instruction
- Bit manipulation instruction
- 63 powerful instructions

General Description

The HT48R50-1/HT48R50-2 is an 8-bit high performance RISC-like microcontroller designed for multiple I/O product applications. The device is particularly suitable for use in products such as remote controllers, fan/light controllers, washing machine controllers, scales, toys and various subsystem controllers.

A halt feature is included to reduce power consumption.

The program and option PROM can be electrically programmed making the HT48R50-1/HT48R50-2 suitable for use in product development.

Block Diagram

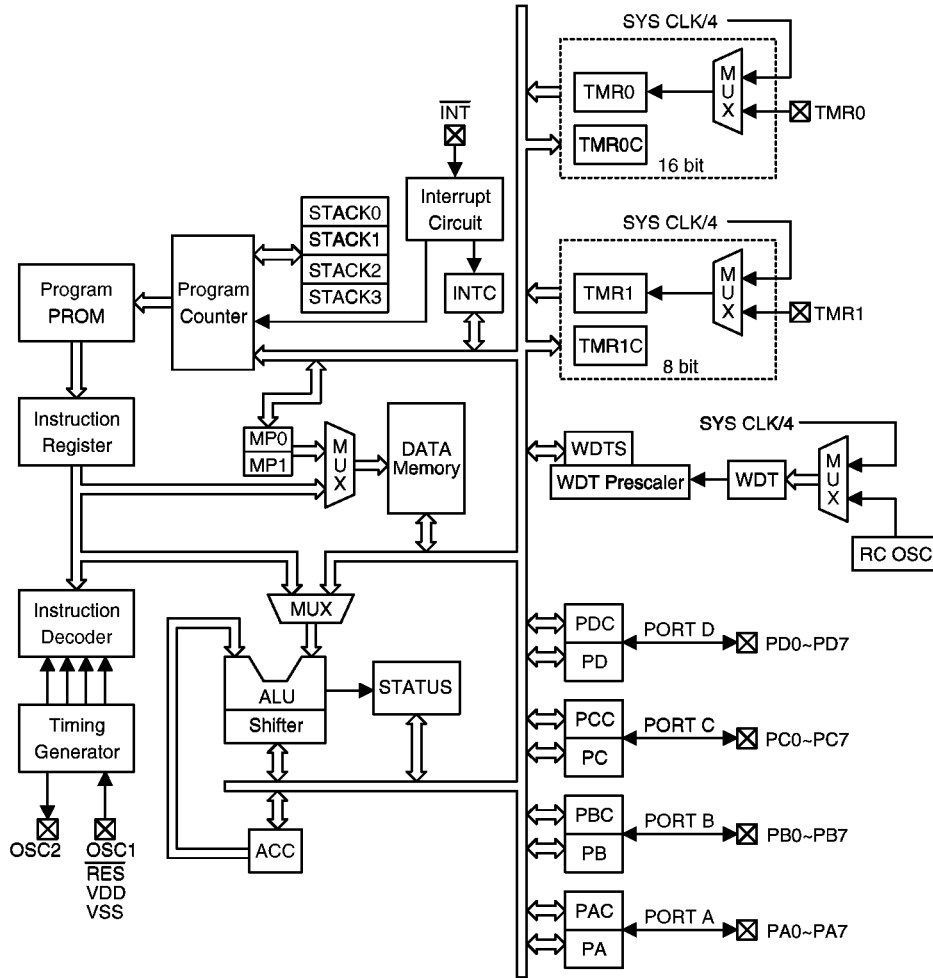

Pin Assignment

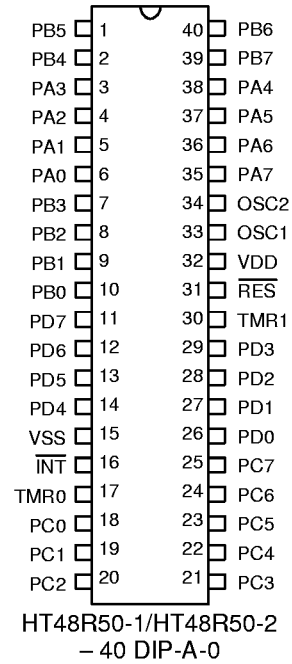
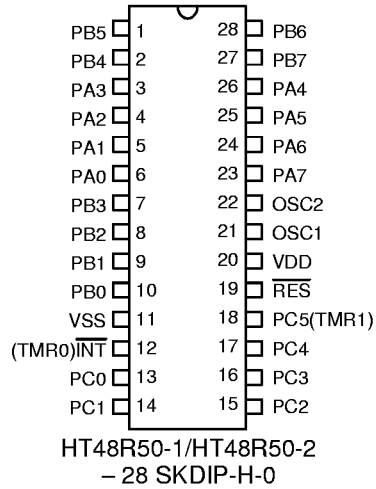

Notes: For Dice form, the TMR0 and TMR1 pads must be bonded to VDD or VSS if the TMR0 and/or TMR1 pads are not used.

The (TMR0) $\overline{\text{INT}}$ indicates that the TMR0 pad must be bonded to the $\overline{\text{INT}}$ pad.

The PC5(TMR1) indicates that the TMR1 pad must be bonded to the PC5 pad.

Pin Description

Pin Name	I/O	ROM Code Option	Description
PA0~PA7	I/O	Wake-up	Bidirectional 8-bit input/output port. Each bit can be configured as wake-up input by ROM code option. Software instructions determine the CMOS output or schmitt trigger input with pull-high resistor.
PB0~PB7	I/O	—	Bidirectional 8-bit input/output port. Software instructions determine the CMOS output or schmitt trigger input with pull-high resistor.
VSS	—	—	Negative power supply, GND
$\overline{\text{INT}}$	I	—	External interrupt schmitt trigger input with pull-high resistor. Edge triggered activated on high to low transition.
TMR0	I	—	Schmitt trigger input for timer/event counter 0
TMR1	I	—	Schmitt trigger input for timer/event counter 1
PC0~PC7	I/O	—	Bidirectional 8-bit input/output port. Software instructions determine the CMOS output or schmitt trigger input with pull-high resistor.
$\overline{\text{RES}}$	I	—	Schmitt trigger reset input. Active low.
VDD	—	—	Positive power supply
OSC1 OSC2	I O	Crystal or RC	OSC1, OSC2 are connected to an RC network or a crystal (determined by ROM code option) for the internal system clock. In the case of RC operation, OSC2 is the output terminal for 1/4 system clock.
PD0~PD7	I/O	—	Bidirectional 8-bit input/output port. Software instructions determine the CMOS output or schmitt trigger input with pull-high resistor.

Absolute Maximum Ratings*

Supply Voltage -0.3V to 5.5V Input Voltage..... $V_{SS}-0.3V$ to $V_{DD}+0.3V$
Storage Temperature..... -50°C to 125°C Operating Temperature..... -25°C to 70°C

*Note: These are stress ratings only. Stresses exceeding the range specified under “Absolute Maximum Ratings” may cause substantial damage to the device. Functional operation of this device at other conditions beyond those listed in the specification is not implied and prolonged exposure to extreme conditions may affect device reliability.

D.C. Characteristics
HT48R50-1
Ta=25°C

Symbol	Parameter	Test Conditions		Min.	Typ.	Max.	Unit
		V _{DD}	Conditions				
V _{DD}	Operating Voltage	—	—	3.0	—	5.2	V
I _{DD1}	Operating Current (Crystal OSC)	3V	No load, f _{SYS} =2MHz	—	0.7	1.5	mA
		5V		—	2	3	mA
I _{DD2}	Operating Current (RC OSC)	3V	No load, f _{SYS} =2MHz	—	0.5	1	mA
		5V		—	2	3	mA
I _{STB1}	Standby Current (WDT Enabled)	3V	No load, system HALT	—	—	5	μA
		5V		—	—	10	μA
I _{STB2}	Standby Current (WDT Disabled)	3V	No load, system HALT	—	—	1	μA
		5V		—	—	2	μA
V _{IL1}	Input Low Voltage for I/O Ports	3V	—	0	—	0.9	V
		5V	—	0	—	1.5	V
V _{IH1}	Input High Voltage for I/O Ports	3V	—	2.1	—	3	V
		5V	—	3.5	—	5	V
V _{IL2}	Input Low Voltage (TMR0, TMR1, $\overline{\text{INT}}$)	3V	—	0	—	0.7	V
		5V	—	0	—	1.3	V
V _{IH2}	Input High Voltage (TMR0, TMR1, INT)	3V	—	2.3	—	3	V
		5V	—	3.8	—	5	V
V _{IL3}	Input Low Voltage (RES)	3V	—	—	1.5	—	V
		5V	—	—	2.5	—	V
V _{IH3}	Input High Voltage (RES)	3V	—	—	2.4	—	V
		5V	—	—	4.0	—	V
I _{OL}	I/O Port Sink Current	3V	V _{DD} =3V, V _{OL} =0.3V	1.5	4	—	mA
		5V	V _{DD} =5V, V _{OL} =0.5V	4	10	—	mA
I _{OH}	I/O Port Source Current	3V	V _{DD} =3V, V _{OH} =2.7V	-1	-2	—	mA
		5V	V _{DD} =5V, V _{OH} =4.5V	-2	-4.5	—	mA
R _{PH}	I/O Port Pull-high Resistance and $\overline{\text{INT}}$	3V	—	40	60	80	kΩ
		5V	—	10	30	50	kΩ

HT48R50-2

Ta=25°C

Symbol	Parameter	Test Conditions		Min.	Typ.	Max.	Unit
		V _{DD}	Conditions				
V _{DD}	Operating Voltage	—	—	2.4	—	4.0	V
I _{DD1}	Operating Current (Crystal OSC)	3V	No load, f _{sys} =2MHz	—	0.7	1.5	mA
I _{DD2}	Operating Current (RC OSC)	3V	No load, f _{sys} =2MHz	—	0.5	1	mA
I _{STB1}	Standby Current (WDT Enabled)	3V	No load, system HALT	—	—	5	μA
I _{STB2}	Standby Current (WDT Disabled)	3V	No load, system HALT	—	—	1	μA
V _{IL1}	Input Low Voltage for I/O Ports	3V	—	0	—	0.9	V
V _{IH1}	Input High Voltage for I/O Ports	3V	—	2.1	—	3	V
V _{IL2}	Input Low Voltage (TMR0, TMR1, $\overline{\text{INT}}$)	3V	—	0	—	0.7	V
V _{IH2}	Input High Voltage (TMR0, TMR1, $\overline{\text{INT}}$)	3V	—	2.3	—	3	V
V _{IL3}	Input Low Voltage ($\overline{\text{RES}}$)	3V	—	—	1.5	—	V
V _{IH3}	Input High Voltage ($\overline{\text{RES}}$)	3V	—	—	2.4	—	V
I _{OL}	I/O Port Sink Current	3V	V _{DD} =3V, V _{OL} =0.3V	1.5	4	—	mA
I _{OH}	I/O Port Source Current	3V	V _{DD} =3V, V _{OH} =2.7V	-1	-2	—	mA
R _{PH}	I/O Port Pull-high Resistance and $\overline{\text{INT}}$	3V	—	40	60	80	kΩ

A.C. Characteristics
HT48R50-1
Ta=25°C

Symbol	Parameter	Test conditions		Min.	Typ.	Max.	Unit
		VDD	Conditions				
f _{SYS1}	System Clock (Crystal OSC)	3V	—	400	—	2000	kHz
		5V	—	400	—	4000	kHz
f _{SYS2}	System Clock (RC OSC)	3V	—	400	—	2000	kHz
		5V	—	400	—	3000	kHz
f _{TIMER}	Timer I/P Frequency (TMR0, TMR1)	3V	—	0	—	2000	kHz
		5V	—	0	—	4000	kHz
t _{WDTOSC}	Watchdog Oscillator	3V	—	45	90	180	μs
		5V	—	35	65	130	μs
t _{WDT1}	Watchdog Time-out Period (RC)	3V	Without WDT prescaler	12	23	45	ms
		5V		9	17	35	ms
t _{WDT2}	Watchdog Time-out Period (System Clock)	—	Without WDT prescaler	—	1024	—	t _{SYS}
t _{RES}	External Reset Low Pulse Width	—	—	1	—	—	μs
t _{SST}	System Start-up Timer Period	—	Power-up or wake-up from halt	—	1024	—	t _{SYS}
t _{INT}	Interrupt Pulse Width	—	—	1	—	—	μs

 Note: t_{SYS}=1/f_{SYS}

HT48R50-2

Ta=25°C

Symbol	Parameter	Test conditions		Min.	Typ.	Max.	Unit
		V _{DD}	Conditions				
f _{SYS1}	System Clock (Crystal OSC)	3V	—	400	—	2000	kHz
f _{SYS2}	System Clock (RC OSC)	3V	—	400	—	2000	kHz
f _{TIMER}	Timer I/P Frequency (TMR0, TMR1)	3V	—	0	—	2000	kHz
t _{WDTOSC}	Watchdog Oscillator	3V	—	45	90	180	μs
t _{WDT1}	Watchdog Time-out Period (RC)	3V	Without WDT prescaler	12	23	45	ms
t _{WDT2}	Watchdog Time-out Period (System Clock)	—	Without WDT prescaler	—	1024	—	t _{SYS}
t _{RES}	External Reset Low Pulse Width	—	—	1	—	—	μs
t _{SST}	System Start-up Timer Period	—	Power-up or wake-up from halt	—	1024	—	t _{SYS}
t _{INT}	Interrupt Pulse Width	—	—	1	—	—	μs

Functional Description

Execution flow

The system clock for the HT48R50-1/HT48R50-2 is derived from either a crystal or an RC oscillator. The system clock is internally divided into four non-overlapping clocks denoted by P1, P2, P3 and P4. One instruction cycle consists of T1 to T4.

Instruction fetching and execution are pipelined in such a way that a fetch takes one instruction cycle while decoding and execution takes the next instruction cycle. However, the pipelining scheme causes each instruction to effectively execute in one cycle. If an instruction changes the program counter, two cycles are required to complete the instruction.

Program counter – PC

The 12-bit program counter (PC) controls the sequence in which the instructions stored in program ROM are executed and its contents specify a maximum of 4096 addresses.

After accessing a program memory word to fetch an instruction code, the contents of the program counter are incremented by one. The program counter then points to the memory word containing the next instruction code.

When executing a jump instruction, conditional skip execution, loading PCL register, subroutine call, initial reset, internal interrupt, external interrupt or return from subroutine, the PC manipulates the program transfer by loading the address corresponding to each instruction.

The conditional skip is activated by instruction. Once the condition is met, the next instruction, fetched during the current instruction execution, is discarded and a dummy cycle replaces it to get the proper instruction. Otherwise proceed with the next instruction.

The lower byte of the program counter (PCL) is a readable and writeable register (06H). Moving data into the PCL performs a short jump. The destination will be within 256 locations.

When a control transfer takes place, an additional dummy cycle is required.

Program memory – PROM

The program memory is used to store the program instructions which are to be executed. It also contains data, table, and interrupt entries, and is organized 4096 × 15 bits, addressed by the program counter and table pointer.

Certain locations in the program memory are reserved for special usage:

- Location 000H
This area is reserved for the initialization program. After chip reset, the program always begins execution at location 000H.
- Location 004H
This area is reserved for the external interrupt service program. If the $\overline{\text{INT}}$ input pin is activated, and the interrupt is enabled and the stack is not full, the program begins execution at location 004H.

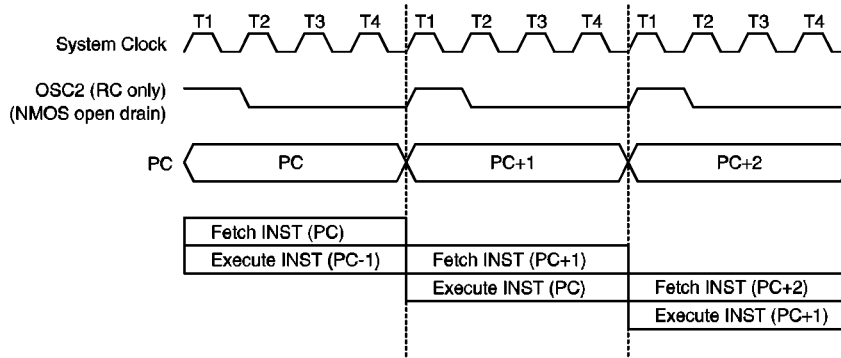

Execution flow

- Location 008H
This area is reserved for the timer/event counter 0 interrupt service program. If timer interrupt results from a timer/event counter overflow, and if the interrupt is enabled and the stack is not full, the program begins execution at location 008H.
- Location 00CH
This area is reserved for the timer/event counter 1 interrupt service program. If timer interrupt resulting from a timer/event counter 1 overflow, and if the interrupt is enabled and the stack is not full, the program begins execution at location 00CH.
- Table location
Any location in the PROM space can be used as look-up tables. The instructions "TABRDC [m]" (the current page, 1 page=256 words) and "TABRDL [m]" (the last page) transfer the contents of the lower-order byte to the specified data memory, and the higher-order byte to TBLH (08H). Only the destination of the lower-order byte in the table is well-defined, the other bits of the table word are transferred to the lower portion of TBLH, the remaining one bit is read as "0". The table higher-order byte register (TBLH) is read

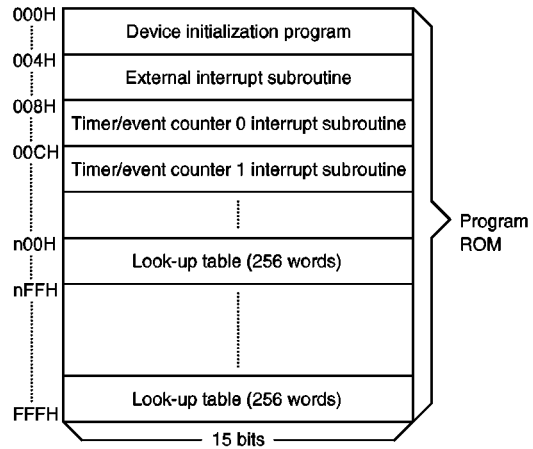

Note: n ranges from 0 to F

Program memory

only. The table pointer (TBLP) is a read/write register (07H), which indicates the table location. Before accessing the table, the location must be placed in TBLP. The TBLH is read only and cannot be restored. If the main routine and the interrupt service routine (ISR) both employ the table read instruction, the contents of the TBLH in the main routine are likely to be changed by the table read instruction used in

Mode	Program Counter											
	*11	*10	*9	*8	*7	*6	*5	*4	*3	*2	*1	*0
Initial reset	0	0	0	0	0	0	0	0	0	0	0	0
External interrupt	0	0	0	0	0	0	0	0	0	1	0	0
Timer/event counter 0 overflow	0	0	0	0	0	0	0	0	1	0	0	0
Timer/event counter 1 overflow	0	0	0	0	0	0	0	0	1	1	0	0
Skip	PC+2											
Loading PCL	*11	*10	*9	*8	@7	@6	@5	@4	@3	@2	@1	@0
Jump, call branch	#11	#10	#9	#8	#7	#6	#5	#4	#3	#2	#1	#0
Return from subroutine	S11	S10	S9	S8	S7	S6	S5	S4	S3	S2	S1	S0

Program counter

Notes: *11~*0: Program counter bits
#11~#0: Instruction code bits

S11~S0: Stack register bits
@7~@0: PCL bits

the ISR. Errors can occur. In other words, using the table read instruction in the main routine and the ISR simultaneously should be avoided. However, if the table read instruction has to be applied in both the main routine and the ISR, the interrupt is supposed to be disabled prior to the table read instruction. It will not be enabled until the TBLH has been backed up. All table related instructions need two cycles to complete the operation. These areas may function as normal program memory depending upon the requirements.

Stack register – STACK

This is a special part of the memory which is used to save the contents of the program counter (PC) only. The stack is organized into four levels and is neither part of the data nor part of the program space, and is neither readable nor writeable. The activated level is indexed by the stack pointer (SP) and is neither readable nor writeable. At a subroutine call or interrupt acknowledgment, the contents of the program counter are pushed onto the stack. At end of a subroutine or an interrupt routine, signaled by a return instruction (RET or RETI), the program counter is restored to its previous value from the stack. After a chip reset, the SP will point to the top of the stack.

If the stack is full and a non-masked interrupt takes place, the interrupt request flag will be recorded but the acknowledgment will be inhibited. When the stack pointer is decremented (by RET or RETI), the interrupt will be serviced. This feature prevents stack overflow allowing the programmer to use the structure more easily. In a similar case, if the stack is full and a “CALL” is

subsequently executed, stack overflow occurs and the first entry will be lost (only the most recent four return addresses are stored).

Data memory – RAM

The data memory is designed with 184×8 bits. The data memory is divided into two functional groups: special function registers and general purpose data memory (160×8). Most of them are read/write, but some are read only.

The special function registers include the indirect addressing register 0 (00H), the memory pointer register 0 (MP0;01H), the indirect addressing register 1 (02H) the memory pointer register 1 (MP1;03H), the accumulator (ACC;05H), the program counter lower-byte register (PCL;06H), the table pointer (TBLP;07H), the table higher-order byte register (TBLH;08H), the watchdog timer option setting register (WDTS;09H), the status register (STATUS;0AH), the interrupt control register (INTC;0BH), the timer/event counter 0 higher-order byte register (TMR0H;0CH), the timer/event counter 0 lower-order byte register (TMR0L;0DH), the timer/event counter 0 control register (TMR0C;0EH), the timer/event counter 1 (TMR1;10H), the timer/event counter 1 control register (TMR1C;11H), the I/O registers (PA;12H, PB;14H, PC;16H, PD;18H) and the I/O control registers (PAC;13H, PBC;15H, PCC;17H, PDC;19H). The remaining space before the 60H is reserved for future expanded usage and reading these locations will get “00H”. The general purpose data memory, addressed from 60H to FFH, is used for data and control information under instruction command.

Instruction(s)	Table Location											
	*11	*10	*9	*8	*7	*6	*5	*4	*3	*2	*1	*0
TABRDC [m]	P11	P10	P9	P8	@7	@6	@5	@4	@3	@2	@1	@0
TABRDL [m]	1	1	1	1	@7	@6	@5	@4	@3	@2	@1	@0

Table location

Notes: *11~*0: Table location bits

P11~P8: Current program counter bits

@7~@0: Table pointer bits

All data memory areas can handle arithmetic, logic, increment, decrement and rotate operations directly. Except for some dedicated bits, each bit in the data memory can be set and reset by "SET [m].i" and "CLR [m].i". They are also indirectly accessible through memory pointer registers (MP0;01H, MP1;03H).

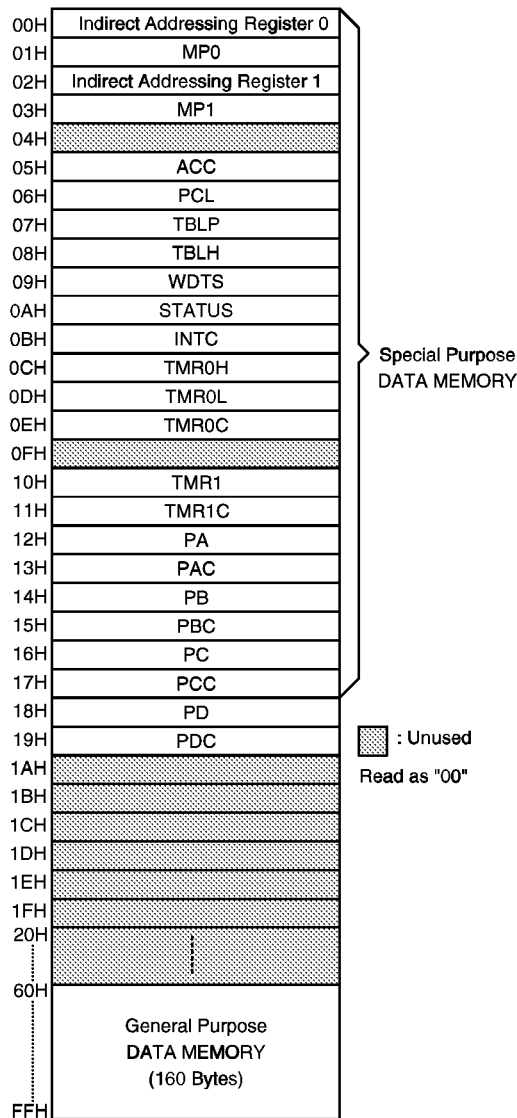

RAM mapping

Indirect addressing register

Location 00H and 02H are indirect addressing registers that are not physically implemented. Any read/write operation of [00H] and [02H] access data memory pointed to by MP0 (01H) and MP1 (03H) respectively. Reading location 00H or 02H indirectly will return the result 00H. Writing indirectly results in no operation.

The function of data movement between two indirect addressing registers, is not supported. The memory pointer registers, MP0 and MP1, are 8-bit register which can be used to access the data memory by combining corresponding Indirect addressing registers.

Accumulator

The accumulator is closely related to ALU operations. It is also mapped to location 05H of the data memory and is capable of carrying out immediate data operations. The data movement between two data memory locations must pass through the accumulator.

Arithmetic and logic unit – ALU

This circuit performs 8-bit arithmetic and logic operation. The ALU provides the following functions:

- Arithmetic operations (ADD, ADC, SUB, SBC, DAA)
- Logic operations (AND, OR, XOR, CPL)
- Rotation (RL, RR, RLC, RRC)
- Increment and Decrement (INC, DEC)
- Branch decision (SZ, SNZ, SIZ, SDZ)

The ALU not only saves the results of a data operation but can also change the status register.

Status register - STATUS

This 8-bit register (0AH) contains the zero flag (Z), carry flag (C), auxiliary carry flag (AC), overflow flag (OV), power down flag (PD), watchdog time-out flag (TO). It also records the status information and controls the operation sequence.

With the exception of the TO and PD flags, bits in the status register can be altered by instructions like most other registers. Any data written into the status register will not change the

TO or PD flags. In addition, operations related to the status register may give different results from those intended. The TO and PD flags can only be changed by system power up, WDT time-out or executing the "CLR WDT" or "HALT" instruction.

The Z, OV, AC and C flags generally reflect the status of the latest operations.

In addition, on entering the interrupt sequence or executing the subroutine call, the status register will not be pushed onto the stack automatically. If the contents of status are important and if the subroutine can corrupt the status register, precautions must be taken to save it properly.

Interrupt

The HT48R50-1/HT48R50-2 provides an external interrupt and internal timer/event counter interrupts. The interrupt control register (INTC;0BH) contains the interrupt control bits to set the enable/disable and the interrupt request flags.

Once an interrupt subroutine is serviced, all other interrupts will be blocked (by clearing the

EMI bit). This scheme may prevent any further interrupt nesting. Other interrupt requests may happen during this interval but only the interrupt request flag is recorded. If a certain interrupt needs servicing within the service routine, the EMI bit and the corresponding bit of INTC may be set to allow interrupt nesting. If the stack is full, the interrupt request will not be acknowledged, even if the related interrupt is enabled, until the SP is decremented. If immediate service is desired, the stack must be prevented from becoming full.

All these kinds of interrupt have a wake-up capability. As an interrupt is serviced, a control transfer occurs by pushing the program counter onto the stack and then branching to subroutines at specified location(s) in the program memory. Only the program counter is pushed onto the stack. If the contents of the register or status register (STATUS) are altered by the interrupt service program which corrupt the desired control sequence, the contents must be saved first.

External interrupts are triggered by a high to low transition of INT and the related interrupt request flag (EIF; bit 4 of INTC) will be set.

Labels	Bits	Function
C	0	C is set if the operation results in a carry during an addition operation or if a borrow does not take place during a subtraction operation; otherwise C is cleared. C is also affected by a rotate through carry instruction.
AC	1	AC is set if the operation results in a carry out of the low nibbles in addition or no borrow from the high nibble into the low nibble in subtraction; otherwise AC is cleared.
Z	2	Z is set if the result of an arithmetic or logic operation is zero; otherwise Z is cleared.
OV	3	OV is set if the operation results in a carry into the highest-order bit but not a carry out of the highest-order bit, or vice versa; otherwise OV is cleared.
PD	4	PD is cleared when either a system power-up or executing the "CLR WDT" instruction. PD is set by executing the "HALT" instruction.
TO	5	TO is cleared by a system power-up or executing the "CLR WDT" or "HALT" instructions. TO is set by a WDT time-out.
—	6	Undefined, read as "0"
—	7	Undefined, read as "0"

STATUS register

When the interrupt is enabled, and the stack is not full and the external interrupt is active, a subroutine call to location 04H will occur. The interrupt request flag (EIF) and EMI bits will be cleared to disable other interrupts.

The internal timer/event counter 0 interrupt is initialized by setting the timer/event counter 0 interrupt request flag (T0F; bit 5 of INTC), caused by a timer/event counter 0 overflow. When the interrupt is enabled, and the stack is not full and the T0F bit is set, a subroutine call to location 08H will occur. The related interrupt request flag (T0F) will be reset and the EMI bit cleared to disable further interrupts.

The timer/event counter 1 interrupt is operated in the same manner as the timer/event counter 0. The related interrupt control bits ET1I and T1F of timer/event counter 1 are bit 3 and bit 6 of INTC respectively.

During the execution of an interrupt subroutine, other interrupt acknowledgments are held until the "RETI" instruction is executed or the EMI bit and the related interrupt control bit are set to 1 (if the stack is not full). To return from the interrupt subroutine, "RET" or "RETI" may be invoked. RETI will set the EMI bit to enable an interrupt service, but RET will not.

Interrupts occurring in the interval between the rising edges of two consecutive T2 pulses, will be serviced on the latter of the two T2 pulses, if the corresponding interrupts are enabled. In the case of simultaneous requests the following table shows the priority that is applied. These can be masked by resetting the EMI bit.

No.	Interrupt Source	Priority	Vector
a	External interrupt	1	04H
b	Timer/event counter 0 overflow	2	08H
c	Timer/event counter 1 overflow	3	0CH

The timer/event counter 0/1 interrupt request flag (T0F/T1F), external interrupt request flag (EIF), enable timer/event counter 0/1 bit (ET0I/ET1I), enable external interrupt bit (EEI) and enable master interrupt bit (EMI) constitute an interrupt control register (INTC) which is located at 0BH in the data memory. EMI, EEI, ET0I, ET1I are used to control the enabling/disabling of interrupts. These bits prevent the requested interrupt being serviced. Once the interrupt request flags (T0F, T1F,

Register	Bit No.	Label	Function
INTC (0BH)	0	EMI	Controls the master (global) interrupt (1= enabled; 0 =disabled)
	1	EEI	Controls the external interrupt (1= enabled; 0= disabled)
	2	ET0I	Controls the timer/event counter 0 interrupt (1= enabled; 0= disabled)
	3	ET1I	Controls the timer/event counter 1 interrupt (1= enabled; 0= disabled)
	4	EIF	External interrupt request flag. (1= active; 0= inactive)
	5	T0F	Internal timer/event counter 0 request flag (1= active; 0= inactive)
	6	T1F	Internal timer/event counter 1 request flag (1= active; 0= inactive)
	7	—	Unused bit, read as "0"

INTC register

EIF) are set, they will remain in the INTC register until the interrupts are serviced or cleared by a software instruction.

It is recommended that a program doesn't use the "CALL subroutine" within the interrupt subroutine. Interrupts often occur in an unpredictable manner or need to be serviced immediately in some applications, if only one stack is left and enabling the interrupt is not well controlled, once the "CALL" operates in the interrupt subroutine will damage the original control sequence.

Oscillator configuration

There are two oscillator circuits in the HT48R50-1/HT48R50-2.

Both are designed for system clocks; the RC oscillator and the Crystal oscillator, which are determined by the ROM code option. No matter what oscillator type is selected, the signal provides the system clock. The HALT mode stops the system oscillator and ignores an external signal to conserve power.

If an RC oscillator is used, an external resistor between OSC1 and VDD is needed and the resistance must range from 51kΩ to 1MΩ. The system clock, divided by 4, is available on OSC2, which can be used to synchronize external logic. The RC oscillator provides the most cost effective solution. However, the frequency of the oscillation may vary with VDD, temperature and the chip itself due to process variations. It is, therefore, not suitable for timing sensitive operations where accurate oscillator frequency is desired.

If a crystal oscillator is used, a crystal across OSC1 and OSC2 is needed to provide the feedback and phase shift needed for oscillator, no other external components are required. Instead of a crystal, a resonator can also be connected be-

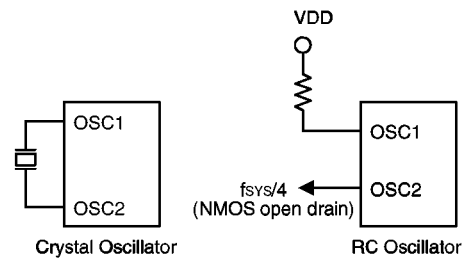

tween OSC1 and OSC2 to get a frequency reference, but two external capacitors in OSC1 and OSC2 are required.

The WDT oscillator is a free running on-chip RC oscillator, and no external components are required. Even if the system enters the power down mode, the system clock is stopped, but the WDT oscillator still works with a period of approximately 78 μs. The WDT oscillator can be disabled by ROM code option to conserve power.

Watchdog timer – WDT

The WDT clock source is implemented by a dedicated RC oscillator (WDT oscillator) or instruction clock (system clock divided by 4), decided by ROM code option. This timer is designed to prevent a software malfunction or sequence jumping to an unknown location with unpredictable results. The watchdog timer can be disabled by a ROM code option. If the watchdog timer is disabled, all the executions related to the WDT result in no operation.

Once the internal WDT oscillator (RC oscillator with period 78μs normally) is selected, it is first divided by 256 (8-stages) to get the nominal time-out period of approximately 20 ms. This time-out period may vary with temperature,

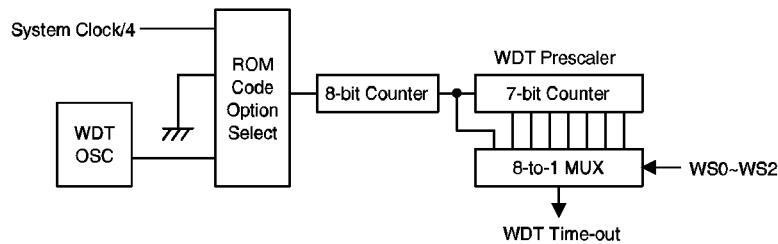

Watchdog timer

VDD and process variations. By invoking the WDT prescaler, longer time-out periods can be realized. Writing data to WS2, WS1, WS0 (bit 2,1,0 of the WDTS) can give different time-out periods. If WS2, WS1, WS0 are all equal to 1, the division ratio is up to 1:128, and the maximum time-out period is 2.6 seconds.

If the WDT oscillator is disabled, the WDT clock may still come from the instruction clock and operate in the same manner except that in the HALT state the WDT may stop counting and lose its protecting purpose. In this situation the logic can only be restarted by external logic. The high nibble and bit 3 of the WDTS are reserved for user defined flags, which may be used to indicate some specified status.

If the device operates in a noisy environment, using the on-chip RC oscillator (WDT OSC) is strongly recommended, since the HALT will stop the system clock.

WS2	WS1	WS0	Division Ratio
0	0	0	1:1
0	0	1	1:2
0	1	0	1:4
0	1	1	1:8
1	0	0	1:16
1	0	1	1:32
1	1	0	1:64
1	1	1	1:128

WDTS register

The WDT overflow under normal operation will initialize “chip reset” and set the status bit “TO”. Whereas in the HALT mode, the overflow will initialize a “warm reset” only the PC and SP are reset to zero. To clear the contents of WDT (including the WDT prescaler), three methods are adopted; external reset (a low level to \overline{RES}), software instruction, or a “HALT” instruction. The software instruction include “CLR WDT” and the other set “CLR WDT1” and “CLR WDT2”. Of these two types of instruction, only one can be active depending on the mask option - “CLR WDT times selection option”. If the “CLR WDT” is selected (i.e. CLRWDT

times equal one), any execution of the “CLR WDT” instruction will clear the WDT. In case “CLR WDT1” and “CLR WDT2” are chosen (i.e. CLRWDT times equal two), these two instructions must be executed to clear the WDT; otherwise, the WDT may reset the chip because of the time-out.

Power down operation – HALT

The HALT mode is initialized by the “HALT” instruction and results in the following...

- The system oscillator will turn off but the WDT oscillator keeps running (if the WDT oscillator is selected).
- The contents of the on-chip RAM and registers remain unchanged.
- WDT and WDT prescaler will be cleared and recount again (if the WDT clock has come from the WDT oscillator).
- All I/O ports maintain their original status.
- The PD flag is set and the TO flag is cleared

The system can leave the HALT mode by means of an external reset, an interrupt, an external falling edge signal on port A or a WDT overflow. An external reset causes a device initialization and the WDT overflow performs a “warm reset”. Examining the TO and PD flags, the reason for chip reset can be determined. The PD flag is cleared when system power-up or executing the “CLR WDT” instruction and is set when the “HALT” instruction is executed. The TO flag is set if the WDT time-out occurs, and causes a wake-up that only resets the PC and SP, the others maintain their original status.

The port A wake-up and interrupt methods can be considered as a continuation of normal execution. Each bit in port A can be independently selected to wake up the device by the ROM code option. Awakening from an I/O port stimulus, the program will resume execution of the next instruction. If awakening from an interrupt, two sequences may happen. If the related interrupt is disabled or the interrupt is enabled but the stack is full, the program will resume execution at the next instruction. If the interrupt is enabled and the stack is not full, the regular interrupt response takes place.

Once a wake-up event occurs, and the system clock comes from a crystal, it takes 1024 t_{SYS} (system clock period) to resume normal operation. In other words, the HT48R50-1/HT48R50-2 will insert a dummy period after a wake-up. If the system clock comes from an RC oscillator, it immediately continue the operation. If the wake-up results from an interrupt acknowledgment, the actual interrupt subroutine execution will delay by one more cycle. If the wake-up results in next instruction execution, this will be executed immediately after the dummy period is finished.

To minimize power consumption, all I/O pins should be carefully managed before entering the HALT status.

Reset

There are three ways in which a reset can occur:

- \overline{RES} reset during normal operation
- \overline{RES} reset during HALT
- WDT time-out reset during normal operation

The WDT time-out during HALT is different from other chip reset conditions, since it can perform a “warm reset” that resets only the PC and SP, leaving the other circuits in their original state. Some registers remain unchanged during any other reset conditions. Most registers are reset to the “initial condition” when the reset conditions are met. By examining the PD and TO flags, the program can distinguish between different “chip resets”.

TO	PD	RESET Conditions
0	0	\overline{RES} reset during power-up
u	u	\overline{RES} reset during normal operation
0	1	\overline{RES} wake-up HALT
1	u	WDT time-out during normal operation
1	1	WDT wake-up HALT

Note: “u” means “unchanged”

To guarantee that the system oscillator has started and stabilized, the XST (System Start-up Timer) can provide an extra-delay of 1024 system clock pulses after system power up or awakes from a HALT state.

When a system power up occurs, the SST delay is added during the reset period. But when the reset comes from the \overline{RES} pin, the SST delay is disabled. Any wake-up from HALT will enable the SST delay.

The functional unit chip reset status are shown below.

PC	000H
Interrupt	Disable
Prescaler	Clear
WDT	Clear. After master reset, WDT begins counting
Timer/event counter (0/1)	Off
Input/output ports	Input mode
SP	Points to the top of the stack

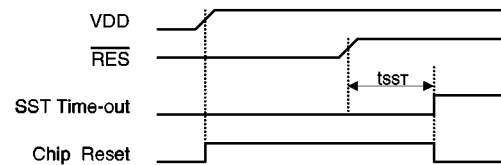

Reset timing chart

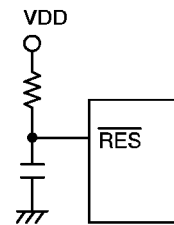

Reset circuit

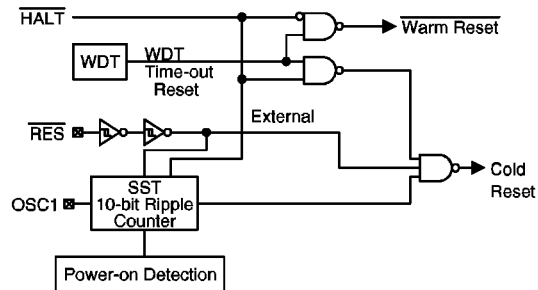

Reset configuration

The state of the registers is summarized in the following table:

Register	Reset (power on)	WDT Time-out (Normal Operation)	$\overline{\text{RES}}$ Reset (Normal Operation)	$\overline{\text{RES}}$ Reset (HALT)	WDT Time- out (HALT)
TMR1	xxxx xxxx	uuuu uuuu	uuuu uuuu	uuuu uuuu	uuuu uuuu
TMR1C	00-0 1---	00-0 1---	00-0 1---	00-0 1---	uu-u u---
TMR0H	xxxx xxxx	uuuu uuuu	uuuu uuuu	uuuu uuuu	uuuu uuuu
TMR0L	xxxx xxxx	uuuu uuuu	uuuu uuuu	uuuu uuuu	uuuu uuuu
TMR0C	00-0 1---	00-0 1---	00-0 1---	00-0 1---	uu-u u---
PC	000H	000H	000H	000H	000H*
MP0	xxxx xxxx	uuuu uuuu	uuuu uuuu	uuuu uuuu	uuuu uuuu
MP1	xxxx xxxx	uuuu uuuu	uuuu uuuu	uuuu uuuu	uuuu uuuu
ACC	xxxx xxxx	uuuu uuuu	uuuu uuuu	uuuu uuuu	uuuu uuuu
TBLP	xxxx xxxx	uuuu uuuu	uuuu uuuu	uuuu uuuu	uuuu uuuu
TBLH	-xxx xxxx	-uuu uuuu	-uuu uuuu	-uuu uuuu	-uuu uuuu
STATUS	--00 xxxx	--1u uuuu	--uu uuuu	--01 uuuu	--11 uuuu
INTC	-000 0000	-000 0000	-000 0000	-000 0000	-uuu uuuu
WDTS	0000 0111	0000 0111	0000 0111	0000 0111	uuuu uuuu
PA	1111 1111	1111 1111	1111 1111	1111 1111	uuuu uuuu
PAC	1111 1111	1111 1111	1111 1111	1111 1111	uuuu uuuu
PB	1111 1111	1111 1111	1111 1111	1111 1111	uuuu uuuu
PBC	1111 1111	1111 1111	1111 1111	1111 1111	uuuu uuuu
PC	1111 1111	1111 1111	1111 1111	1111 1111	uuuu uuuu
PCC	1111 1111	1111 1111	1111 1111	1111 1111	uuuu uuuu
PD	1111 1111	1111 1111	1111 1111	1111 1111	uuuu uuuu
PDC	1111 1111	1111 1111	1111 1111	1111 1111	uuuu uuuu

Notes: "*" means "warm reset"

"u" means "unchanged"

"x" means "unknown"

Timer/event counter

Two timer/event counters are implemented in the HT48R50-1/HT48R50-2. The timer/event counters 0 and 1 contain 16-bit and 8-bit programmable count-up counters respectively and the clock may come from an external source or the system clock divided by 4.

Using the internal instruction clock, there is only one reference time-base. The external clock input allows the user to count external events, measure time intervals or pulse width, or generate an accurate time base.

There are three registers related to the timer/event counter 0; TMR0H (0CH), TMR0L (0DH), TMR0C (0EH). Writing TMR0L only writes the data into a low byte buffer, and writing TMR0H will write the data and the contents of the low byte buffer into the timer/event counter 0 preload register (16-bit) simultaneously. The timer/event counter 0 preload register is changed by writing TMR0H operations and writing TMR0L will keep the timer/event counter 0 preload register unchanged.

Reading TMR0H will also latch the TMR0L into the low byte buffer to avoid the false timing problem. Reading TMR0L returns the contents of the low byte buffer. In other words, the low byte of timer/event counter 0 can not be read directly. It must read the TMR0H first to make

the low byte contents of timer/event counter 0 latched into the buffer.

There are two registers related to the timer/event counter 1; TMR1 (10H), TMR1C (11H). Writing TMR1 makes the starting value be placed in the timer/event counter 1 preload register and reading TMR1 gets the contents of the timer/event counter 1.

The TMR0C is the timer/event counter 0 control register, which defines the timer/event counter 0 options. The timer/event counter 1 has the same options as the timer/event counter 0 and is defined by TMR1C.

The timer/event counter control registers define the operating mode, counting enable or disable and active edge.

The TM0, TM1 bits define the operating mode. The event count mode is used to count external events, which means the clock source comes from an external (TMR0/TMR1) pin. The timer mode functions as a normal timer with the clock source coming from the instruction clock. The pulse width measurement mode can be used to count the high or low level duration of the external signal (TMR0/TMR1). The counting is based on the instruction clock.

In the event count or timer mode, once the timer/event counter starts counting, it will count from the current contents in the

Label (TMR0C/TMR1C)	Bits	Function
—	0~2	Unused bits, read as “0”
TE	3	To define the TMR0/TMR1 active edge of timer/event counter (0=active on low to high; 1=active on high to low)
TON	4	To enable/disable timer counting (0=disabled; 1=enabled)
—	5	Unused bits, is read as “0”
TM0 TM1	6 7	To define the operating mode 01=Event count mode (external clock) 10=Timer mode (internal clock) 11=Pulse width measurement mode 00=Unused

TMR0C/TMR1C register

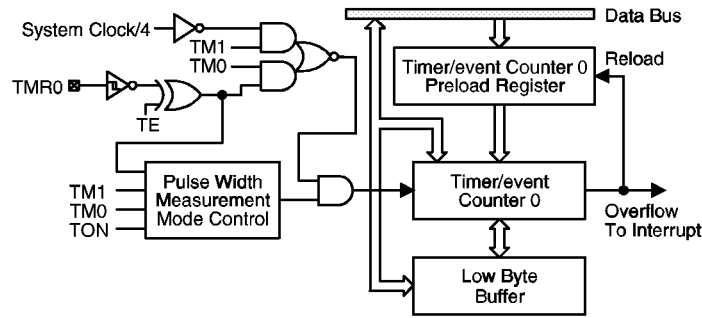

Timer/event counter 0

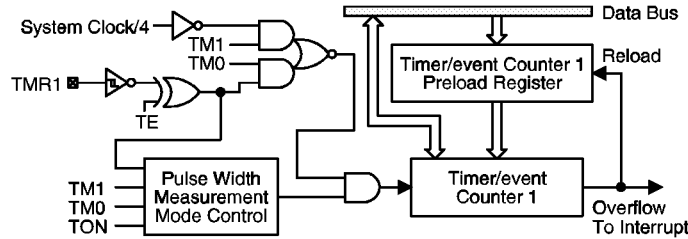

Timer/event counter 1

timer/event counter to FFFFH (TMR0)/FFH (TMR1). Once overflow occurs, the counter is reloaded from the timer/event counter preload register and generates the corresponding interrupt request flag (T0F/T1F; bit 5/6 of INTC) at the same time.

In pulse width measurement mode with the TON and TE bits equal to one, once the TMR0/TMR1 has received a transient from low to high (or high to low; if the TE bit is 0) it will start counting until the TMR0/TMR1 returns to the original level and resets the TON. The measured result will remain in the timer/event counter even if the activated transient occurs again. In other words, only one cycle measurements can be done. Until setting the TON, the cycle measurement will function again as long as it receives further transient pulse. Note that, in this operating mode, the timer/event counter starts counting not according to the logic level but according to the transient edges. In the case of counter overflows, the counter is reloaded from the timer/event counter preload register and issues the interrupt request just like the other two modes.

To enable the counting operation, the timer ON bit (TON; bit 4 of TMR0C/TMR1C) should be set to 1. In the pulse width measurement mode, the TON will be cleared automatically after the measurement cycle is complete. But in the other two modes the TON can only be reset by instruction. The overflow of the timer/event counter is one of the wake-up sources. No matter what the operation mode is, writing a 0 to ET0I/ET1I can disable the corresponding interrupt service.

In the case of timer/event counter OFF condition, writing data to the timer/event counter preload register will also reload that data to timer/event counter. But if the timer/event counter is turned on, data written to the timer/event counter will only be kept in the timer/event counter preload register. The timer/event counter will still operate until the overflow occurs.

When the timer/event counter (reading TMR0H/TMR1) is read, the clock will be blocked to avoid errors. As this may results in a counting error, this must be taken into consideration by the programmer.

Input/output ports

There are 32 bidirectional input/output lines in the HT48R50-1/HT48R50-2, labeled from PA to PD, which are mapped to the data memory of [12H], [14H], [16H] and [18H] respectively. All these I/O ports can be used for input and output operations. For input operation, these ports are non-latching, that is, the inputs must be ready at the T2 rising edge of instruction "MOV A,[m]" (m=12H, 14H, 16H or 18H). For output operation, all data is latched and remains unchanged until the output latch is rewritten.

Each I/O line has it's own control register (PAC, PBC, PCC, PDC) to control the input/output configuration. With this control register, CMOS output or schmitt trigger input with pull-high resistor structures can be reconfigured dynamically (i.e., on-the-fly) under software control. To function as an input, the corresponding latch of the control register must write "1". The pull-high resistance will exhibit automatically. The

input source also depends on the control register. If the control register bit is "1", input will read the pad state. If the control register bit is "0", the contents of the latches will move to the internal bus. The latter is possible in "read-modify-write" instruction. For output function, CMOS is the only configuration. These control registers are mapped to locations 13H, 15H, 17H and 19H.

After a chip reset, these input/output lines remain at high levels. Each bit of these input/output latches can be set or cleared by "SET [m].i" and "CLR [m].i" (m=12H, 14H, 16H or 18H) instructions.

Some instructions first input data and then follow the output operations. For example, "SET [m].i", "CLR [m].i", "CPL [m]", "CPLA [m]" read the entire port states into the CPU, execute the defined operations (bit-operation), and then write the results back to the latches or the accumulator.

Each line of port A has the capability to wake-up the device.

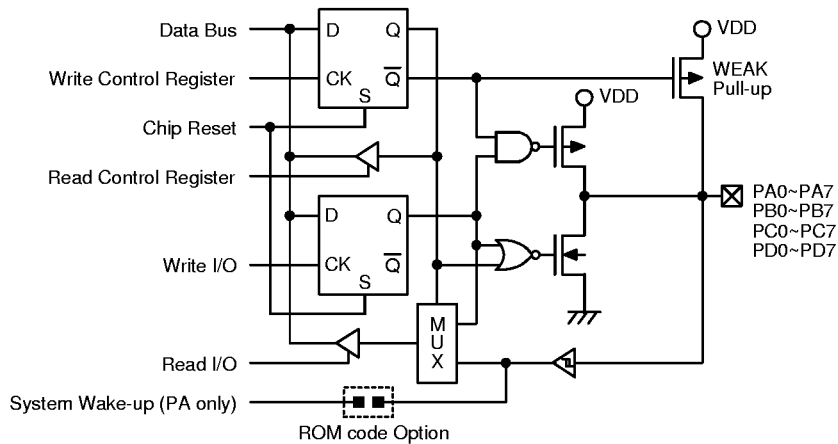

Input/output ports

ROM code option

The following table shows seven kinds of ROM option in the HT48R50-1/HT48R50-2. All the ROM code options must be defined to ensure proper system functioning.

Items	Option	Description
1	OP [7:0]	OP0~OP7→PA0~PA7 Bit=0 Without wake up Bit=1 With wake up
2	OP8	Bit=0 RC mode Bit=1 Crystal mode
3	OP9	Bit=0 Two cycle CLRWDT Bit=1 One cycle CLRWDT
4	OP10	This bit must be set as "0" by default.
5	OP11	This bit must be set as "0" by default.
6	OP12	Bit=0 RC clock for WDT source Bit=1 System clock for WDT source
7	OP13	Bit=0 Enable WDT Bit=1 Disable WDT

PROM programming and verification

The program memory used in the HT48R50-1/HT48R50-2 is arranged into a 4K×15 bits program PROM and a 1×14 bits option PROM. The program code and option code are stored in the program PROM and option PROM. The programming of PROM can be summarized as follows:

- Power on
- Set V_{PP} (\overline{RES}) to 12.5V
- Set \overline{CS} (PA5) to low

Let PA3~PA0 (AD3~AD0) be the address and data bus and the PA4 (CLK) be the clock input. The data on the AD3~AD0 pins will be clocked into or out of the HT48R50-1/HT48R50-2 on the falling edge of PA4 (CLK) for PROM programming and verification.

The address data contains the code address (12 bits) and two option bits. A complete write cycle will contain four CLK cycles. The first cycle, bits 0~3 of the address are latched into the HT48R50-1/HT48R50-2. The second and third cycles, bits 4~7 and bits 8~11 are latched respectively. The fourth cycle, bit 2 is the TSEL option bit and bit 3 is the OSEL option bit. Bit 3 in the third cycle and bits 0~1 in the fourth cycle are undefined. If the TSEL is "1" and the OSEL is "0", the TEST memory will be read. If the TSEL is "0" and the OSEL is "1", the option PROM will be accessed. If both the TSEL and OSEL are "0", the program PROM will be managed.

The code data is 15-bit wide. A complete read/write cycle contains four CLK cycles. In the first cycle, bits 0~3 of the code data are accessed. In the second and third, bits 4~7 and bits 8~11 are accessed respectively. In the fourth cycle, bits 12~14 are accessed. Bit 15 is undefined. During code verification, reading will return the result "0".

Select the TSEL and OSEL to program and verify the program PROM and option PROM. Use the R/W (PA6) to select the programming or verification

The address is automatically incremented by one after a code verification cycle. If the non-successive address programming or verification is accomplished, the automatic addressing increment is disabled. For the non-successive address programming and verification, the \overline{CS} pin must return to high level for a programming or verification cycle, that is, if a non-successive address is managed, the programming or verification cycle must be interrupted and restarted as well.

The related pins of PROM programming and verification are listed in the following table.

Pin Name	Function	Description
PA0	AD0	Bit 0 of address/data bus
PA1	AD1	Bit 1 of address/data bus
PA2	AD2	Bit 2 of address/data bus
PA3	AD3	Bit 3 of address/data bus
PA4	CLK	Serial clock input for address and data
PA5	\overline{CS}	Chip select, active low
PA6	R/ \overline{W}	Read/write control input
\overline{RES}	VPP	Programming the power supply

The timing charts of programming and verification are as shown. There is a LOCK signal for code protection. If the LOCK is "1", reading code will return the result "1". However, if the LOCK is "0", the code protection is disabled and the code can always be read until the LOCK is programmed as "1".

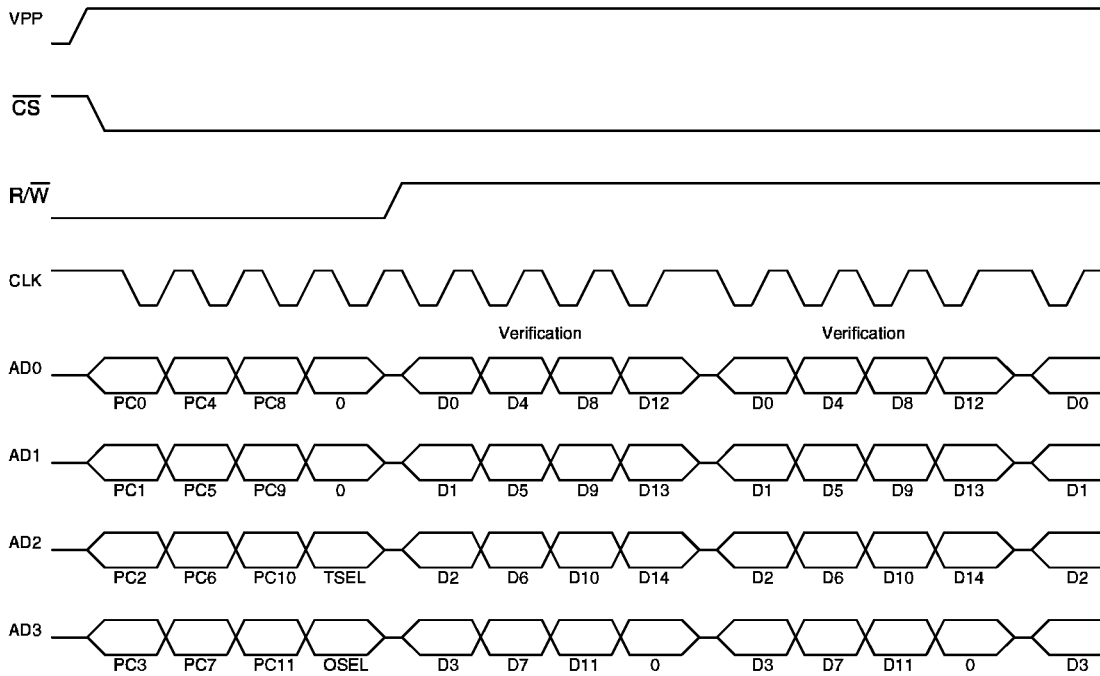

Successive verification

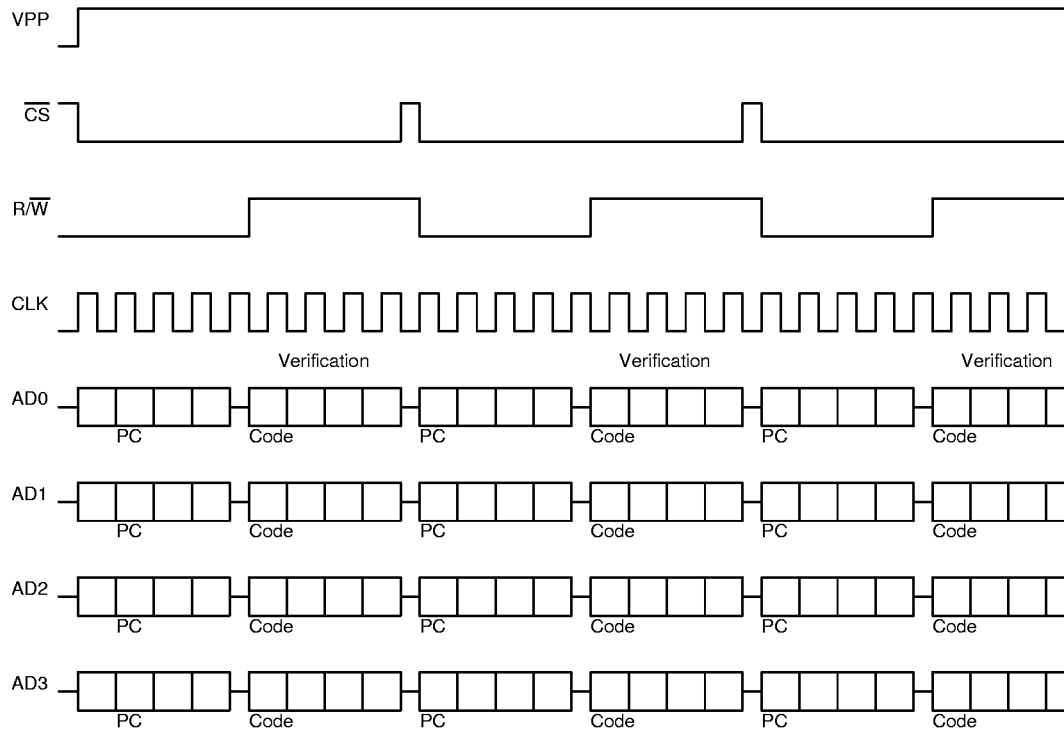

Non-successive verification

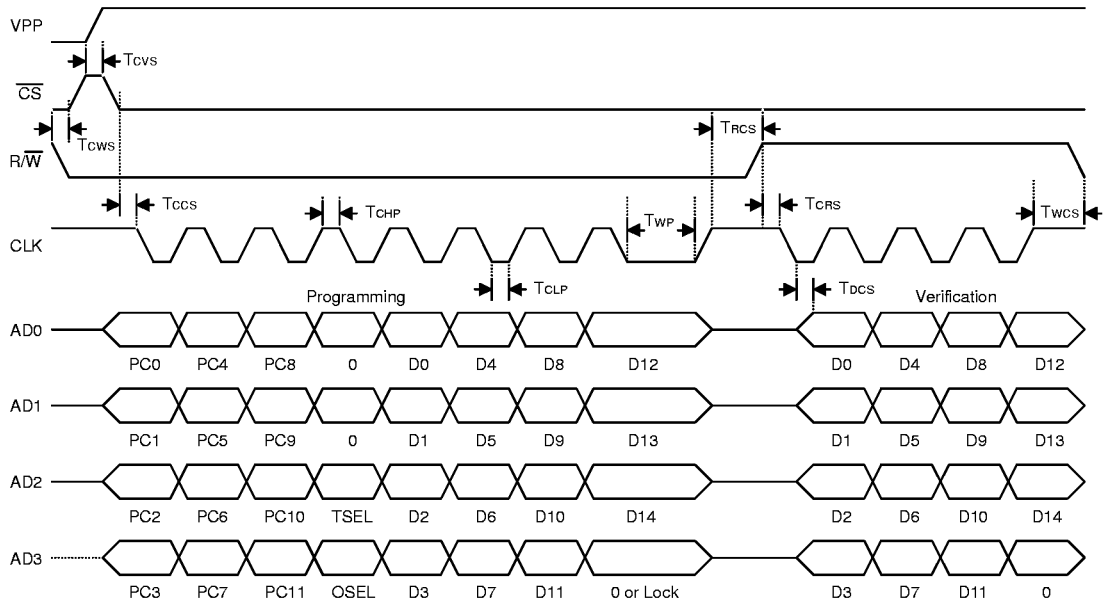

Code programming and verification

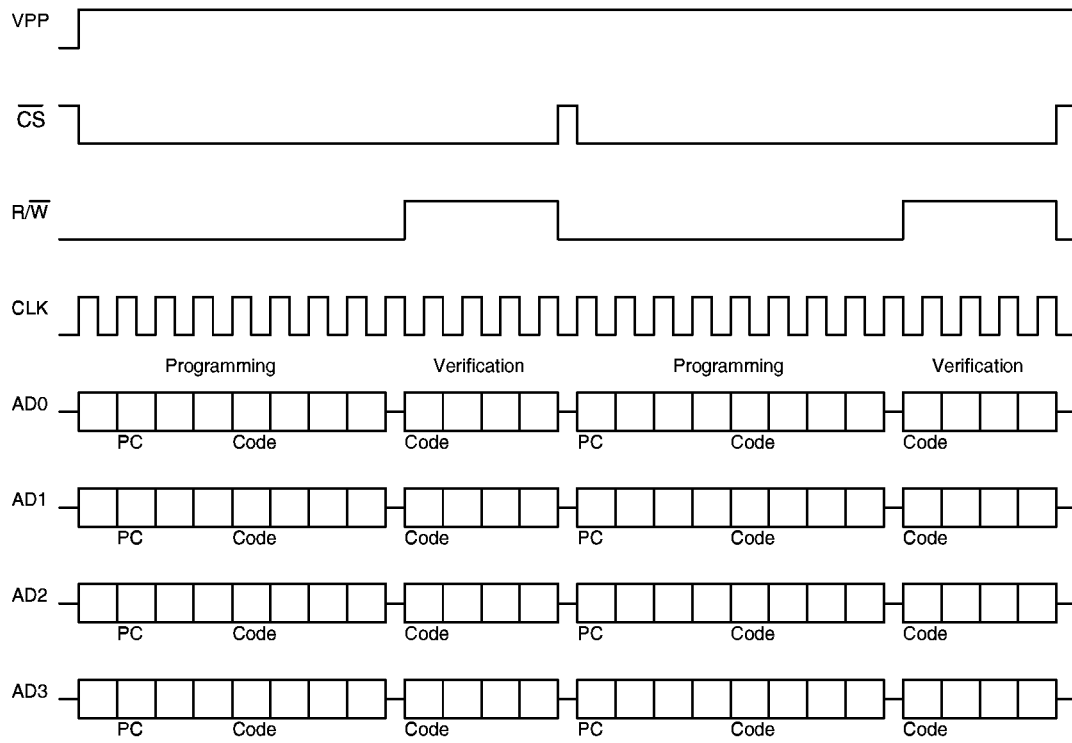

Non-successive programming and verification

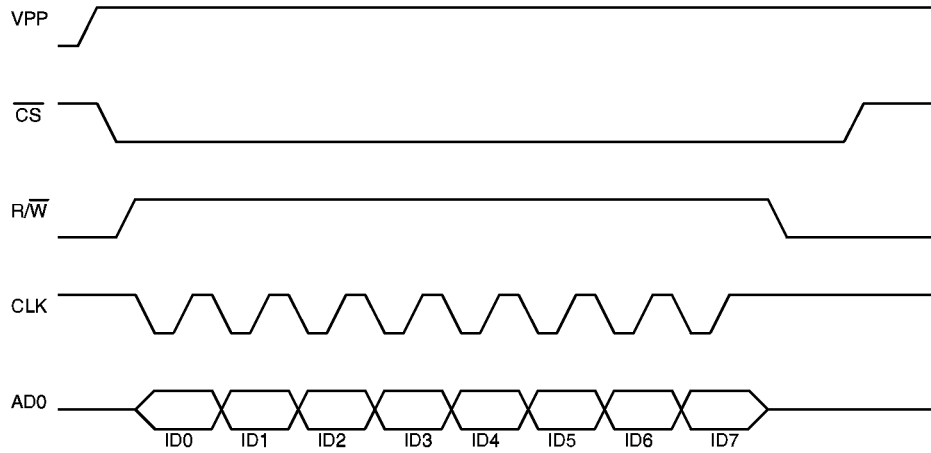

AD1, AD2, AD3 : Don't Care

Code programming and verification

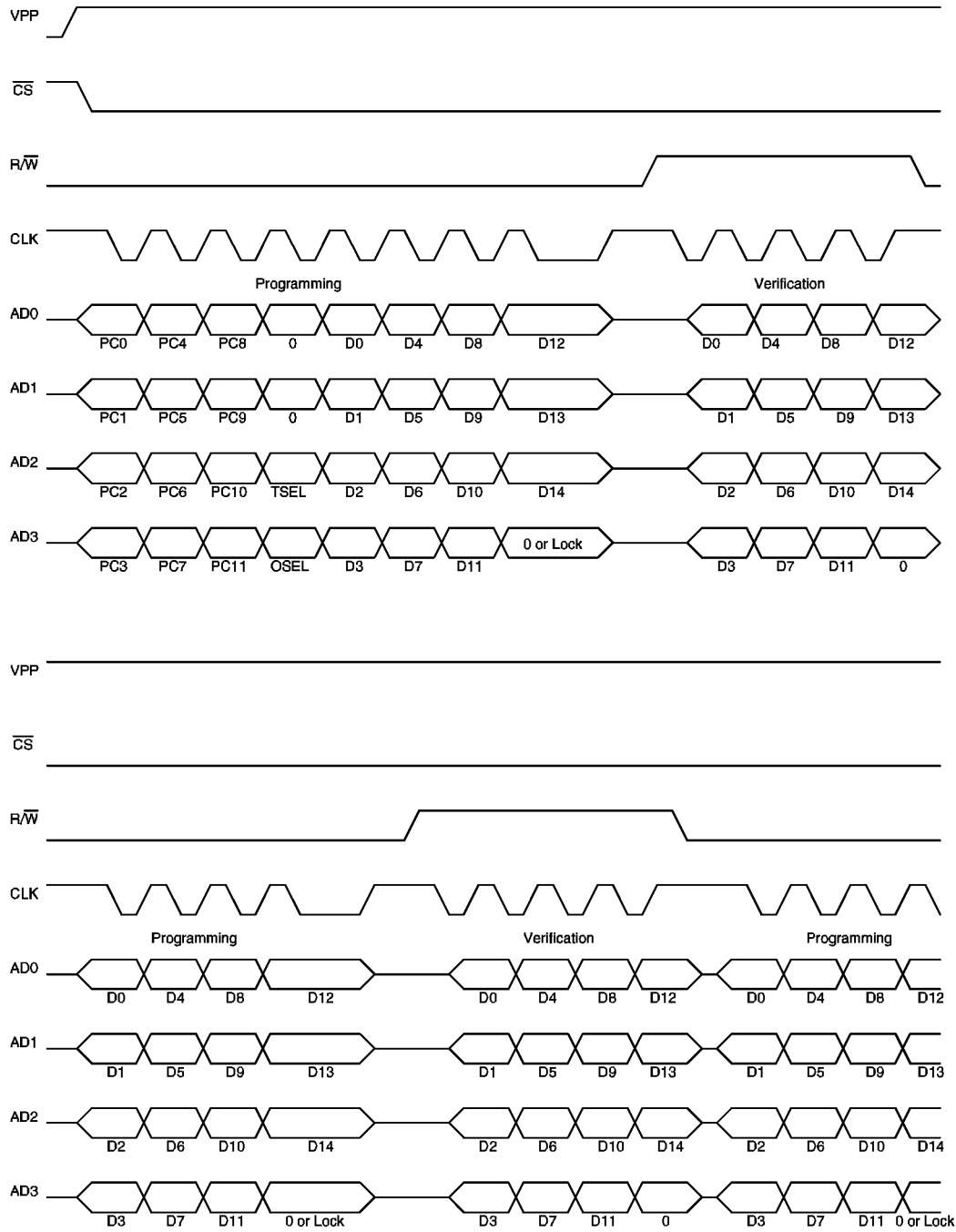

Successive programming and verification

Application Circuits

RC oscillator for multiple I/O applications

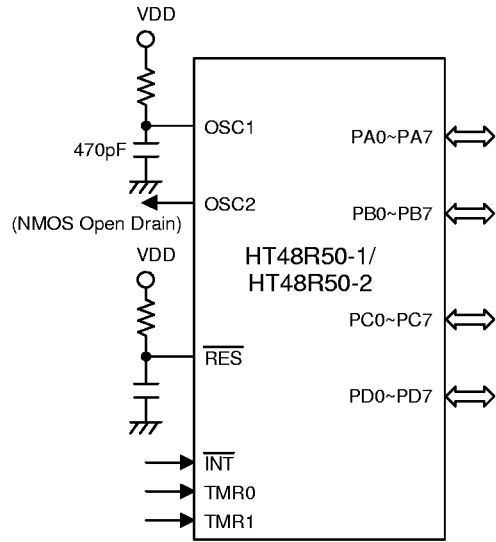

Crystal oscillator or ceramic resonator for multiple I/O applications

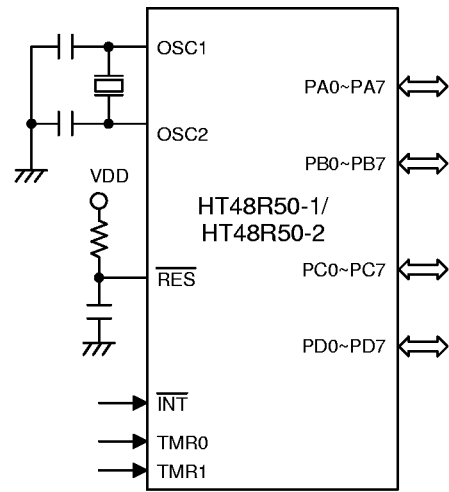

Instruction Set Summary

Mnemonic	Description	Instruction Cycle	Flag Affected
Arithmetic			
ADD A,[m]	Add data memory to ACC	1	Z,C,AC,OV
ADDM A,[m]	Add ACC to data memory	1 ⁽¹⁾	Z,C,AC,OV
ADD A,x	Add immediate data to ACC	1	Z,C,AC,OV
ADC A,[m]	Add data memory to ACC with carry	1	Z,C,AC,OV
ADCM A,[m]	Add ACC to register with carry	1 ⁽¹⁾	Z,C,AC,OV
SUB A,x	Subtract immediate data from ACC	1	Z,C,AC,OV
SUB A,[m]	Subtract data memory from ACC	1	Z,C,AC,OV
SUBM A,[m]	Subtract data memory from ACC with result in data memory	1 ⁽¹⁾	Z,C,AC,OV
SBC A,[m]	Subtract data memory from ACC with carry	1	Z,C,AC,OV
SBCM A,[m]	Subtract data memory from ACC with carry and result in data memory	1 ⁽¹⁾	Z,C,AC,OV
DAA [m]	Decimal adjust ACC for addition with result in data memory	1 ⁽¹⁾	C
Logic Operation			
AND A,[m]	AND data memory to ACC	1	Z
OR A,[m]	OR data memory to ACC	1	Z
XOR A,[m]	Exclusive-OR data memory to ACC	1	Z
ANDM A,[m]	AND ACC to data memory	1 ⁽¹⁾	Z
ORM A,[m]	OR ACC to data memory	1 ⁽¹⁾	Z
XORM A,[m]	Exclusive-OR ACC to data memory	1 ⁽¹⁾	Z
AND A,x	AND immediate data to ACC	1	Z
OR A,x	OR immediate data to ACC	1	Z
XOR A,x	Exclusive-OR immediate data to ACC	1	Z
CPL [m]	Complement data memory	1 ⁽¹⁾	Z
CPLA [m]	Complement data memory with result in ACC	1	Z
Increment & Decrement			
INCA [m]	Increment data memory with result in ACC	1	Z
INC [m]	Increment data memory	1 ⁽¹⁾	Z
DECA [m]	Decrement data memory with result in ACC	1	Z
DEC [m]	Decrement data memory	1 ⁽¹⁾	Z

Mnemonic	Description	Instruction Cycle	Flag Affected
Rotate			
RRA [m]	Rotate data memory right with result in ACC	1	None
RR [m]	Rotate data memory right	1 ⁽¹⁾	None
RRCA [m]	Rotate data memory right through carry with result in ACC	1	C
RRC [m]	Rotate data memory right through carry	1 ⁽¹⁾	C
RLA [m]	Rotate data memory left with result in ACC	1	None
RL [m]	Rotate data memory left	1 ⁽¹⁾	None
RLCA [m]	Rotate data memory left through carry with result in ACC	1	C
RLC [m]	Rotate data memory left through carry	1 ⁽¹⁾	C
Data Move			
MOV A,[m]	Move data memory to ACC	1	None
MOV [m],A	Move ACC to data memory	1 ⁽¹⁾	None
MOV A,x	Move immediate data to ACC	1	None
Bit Operation			
CLR [m].i	Clear bit of data memory	1 ⁽¹⁾	None
SET [m].i	Set bit of data memory	1 ⁽¹⁾	None
Branch			
JMP addr	Jump unconditional	2	None
SZ [m]	Skip if data memory is zero	1 ⁽²⁾	None
SZA [m]	Skip if data memory is zero with data movement to ACC	1 ⁽²⁾	None
SZ [m].i	Skip if bit i of data memory is zero	1 ⁽²⁾	None
SNZ [m].i	Skip if bit i of data memory is not zero	1 ⁽²⁾	None
SIZ [m]	Skip if increment data memory is zero	1 ⁽³⁾	None
SDZ [m]	Skip if decrement data memory is zero	1 ⁽³⁾	None
SIZA [m]	Skip if increment data memory is zero with result in ACC	1 ⁽²⁾	None
SDZA [m]	Skip if decrement data memory is zero with result in ACC	1 ⁽²⁾	None
CALL addr	Subroutine call	2	None
RET	Return from subroutine	2	None
RET A,x	Return from subroutine and load immediate data to ACC	2	None
RETI	Return from interrupt	2	None

Mnemonic	Description	Instruction Cycle	Flag Affected
Table Read			
TABRDC [m]	Read ROM code (current page) to data memory and TBLH	2 ⁽¹⁾	None
TABRDL [m]	Read ROM code (last page) to data memory and TBLH	2 ⁽¹⁾	None
Miscellaneous			
NOP	No operation	1	None
CLR [m]	Clear data memory	1 ⁽¹⁾	None
SET [m]	Set data memory	1 ⁽¹⁾	None
CLR WDT	Clear Watchdog timer	1	TO,PD
CLR WDT1	Pre-clear Watchdog timer	1	TO ⁽⁴⁾ ,PD ⁽⁴⁾
CLR WDT2	Pre-clear Watchdog timer	1	TO ⁽⁴⁾ ,PD ⁽⁴⁾
SWAP [m]	Swap nibbles of data memory	1 ⁽¹⁾	None
SWAPA [m]	Swap nibbles of data memory with result in ACC	1	None
HALT	Enter power down mode	1	TO,PD

Notes: x: 8 bits immediate data

m: 8 bits data memory address

A: accumulator

i: 0~7 number of bits

addr: 12 bits program memory address

√: Flag is affected

–: Flag is not affected

⁽¹⁾: If a loading to the PCL register occurs, the execution cycle of instructions will be delayed one more cycle (four system clocks).

⁽²⁾: If a skipping to the next instruction occurs the execution cycle of instructions will be delayed one more cycle (four system clocks). Otherwise the original instruction cycle is unchanged.

⁽³⁾: ⁽¹⁾ and ⁽²⁾

⁽⁴⁾: The flags may be affected by the execution status. If the watchdog timer is cleared by executing the CLR WDT1 or CLR WDT2 instruction, the TO is set and the PD is cleared. Otherwise the TO and PD flags remain unchanged.

Instruction Definition

ADC A,[m] Add data memory and carry to accumulator
 Description The contents of the specified data memory, accumulator and the carry flag are added simultaneously, leaving the result in the accumulator.

Operation $ACC \leftarrow ACC+[m]+C$

Affected flag(s)

TC2	TC1	TO	PD	OV	Z	AC	C
-	-	-	-	√	√	√	√

ADCM A,[m] Add accumulator and carry to data memory
 Description The contents of the specified data memory, accumulator and the carry flag are added simultaneously, leaving the result in the specified data memory.

Operation $[m] \leftarrow ACC+[m]+C$

Affected flag(s)

TC2	TC1	TO	PD	OV	Z	AC	C
-	-	-	-	√	√	√	√

ADD A,[m] Add data memory to accumulator
 Description The contents of the specified data memory and the accumulator are added. The result is stored in the accumulator.

Operation $ACC \leftarrow ACC+[m]$

Affected flag(s)

TC2	TC1	TO	PD	OV	Z	AC	C
-	-	-	-	√	√	√	√

ADD A,x Add immediate data to accumulator
 Description The contents of the accumulator and the specified data are added, leaving the result in the accumulator.

Operation $ACC \leftarrow ACC+x$

Affected flag(s)

TC2	TC1	TO	PD	OV	Z	AC	C
-	-	-	-	√	√	√	√

ADDM A,[m] Add accumulator to data memory
 Description The contents of the specified data memory and the accumulator are added. The result is stored in the data memory.
 Operation $[m] \leftarrow ACC + [m]$
 Affected flag(s)

TC2	TC1	TO	PD	OV	Z	AC	C
-	-	-	-	√	√	√	√

AND A,[m] Logical AND accumulator with data memory
 Description Data in the accumulator and the specified data memory performs a bitwise logical_AND operation. The result is stored in the accumulator.
 Operation $ACC \leftarrow ACC \text{ "AND" } [m]$
 Affected flag(s)

TC2	TC1	TO	PD	OV	Z	AC	C
-	-	-	-	-	√	-	-

AND A,x Logical AND immediate data to accumulator
 Description Data in the accumulator and the specified data performs a bitwise logical_AND operation. The result is stored in the accumulator.
 Operation $ACC \leftarrow ACC \text{ "AND" } x$
 Affected flag(s)

TC2	TC1	TO	PD	OV	Z	AC	C
-	-	-	-	-	√	-	-

ANDM A,[m] Logical AND data memory with accumulator
 Description Data in the specified data memory and the accumulator performs a bitwise logical_AND operation. The result is stored in the data memory.
 Operation $[m] \leftarrow ACC \text{ "AND" } [m]$
 Affected flag(s)

TC2	TC1	TO	PD	OV	Z	AC	C
-	-	-	-	-	√	-	-

CALL addr Subroutine call
Description The instruction unconditionally calls a subroutine located at the indicated address. The program counter increments once to obtain the address of the next instruction, and pushes this onto the stack. The indicated address is then loaded. Program execution continues with the instruction at this address.

Operation Stack ← PC+1
 PC ← addr

Affected flag(s)

TC2	TC1	TO	PD	OV	Z	AC	C
-	-	-	-	-	-	-	-

CLR [m] Clear data memory
Description The contents of the specified data memory are cleared to zero.

Operation [m] ← 00H

Affected flag(s)

TC2	TC1	TO	PD	OV	Z	AC	C
-	-	-	-	-	-	-	-

CLR [m].i Clear bit of data memory
Description The bit i of the specified data memory is cleared to zero.

Operation [m].i ← 0

Affected flag(s)

TC2	TC1	TO	PD	OV	Z	AC	C
-	-	-	-	-	-	-	-

CLR WDT Clear watchdog timer
Description The WDT and the WDT Prescaler are cleared (re-counting from zero). The power down bit (PD) and time-out bit (TO) are cleared.

Operation WDT and WDT Prescaler ← 00H
 PD and TO ← 0

Affected flag(s)

TC2	TC1	TO	PD	OV	Z	AC	C
-	-	0	0	-	-	-	-

CLR WDT1 Preclear watchdog timer

Description The PD, TO flags, WDT and the WDT Prescaler are cleared (re-counting from zero), if the other preclear WDT instruction had been executed. Only execution of this instruction without the other preclear instruction sets the indicating flag which implies that this instruction was executed and the PD and TO flags remain unchanged.

Operation WDT and WDT Prescaler \leftarrow 00H*
 PD and TO \leftarrow 0*

Affected flag(s)

TC2	TC1	TO	PD	OV	Z	AC	C
–	–	0*	0*	–	–	–	–

CLR WDT2 Preclear watchdog timer

Description The PD, TO flags, WDT and the WDT Prescaler are cleared (re-counting from zero), if the other preclear WDT instruction had been executed. Only execution of this instruction without the other preclear instruction sets the indicating flag which implies this instruction was executed and the PD and TO flags remain unchanged.

Operation WDT and WDT Prescaler \leftarrow 00H*
 PD and TO \leftarrow 0*

Affected flag(s)

TC2	TC1	TO	PD	OV	Z	AC	C
–	–	0*	0*	–	–	–	–

CPL [m] Complement data memory

Description Each bit of the specified data memory is logically complemented (1's complement). Bits which previously contain a one are changed to zero and vice-versa.

Operation [m] \leftarrow $\overline{[m]}$

Affected flag(s)

TC2	TC1	TO	PD	OV	Z	AC	C
–	–	–	–	–	√	–	–

CPLA [m] Complement data memory and place result in accumulator
 Description Each bit of the specified data memory is logically complemented (1's complement). Bits which previously contained a one are changed to zero and vice-versa. The complemented result is stored in the accumulator and the contents of the data memory remains unchanged.

Operation $ACC \leftarrow \overline{[m]}$

Affected flag(s)

TC2	TC1	TO	PD	OV	Z	AC	C
-	-	-	-	-	√	-	-

DAA [m] Decimal-Adjust accumulator for addition
 Description The accumulator value is adjusted to the BCD (Binary Code Decimal) code. The accumulator is divided into two nibbles. Each nibble is adjusted to the BCD code and an internal carry (AC1) will be done if the low nibble of the accumulator is greater than 9. The BCD adjustment is done by adding 6 to the original value if the original value is greater than 9 or a carry (AC or C) is set; otherwise the original value remains unchanged. The result is stored in the data memory and only the carry flag (C) may be affected.

Operation
 If $ACC.3 \sim ACC.0 > 9$ or $AC=1$
 then $[m].3 \sim [m].0 \leftarrow (ACC.3 \sim ACC.0) + 6$, $AC1 = \overline{AC}$
 else $[m].3 \sim [m].0 \leftarrow (ACC.3 \sim ACC.0)$, $AC1 = 0$
 and
 If $ACC.7 \sim ACC.4 > 9$ or $C=1$
 then $[m].7 \sim [m].4 \leftarrow ACC.7 \sim ACC.4 + 6 + AC1$, $C = 1$
 else $[m].7 \sim [m].4 \leftarrow ACC.7 \sim ACC.4 + AC1$, $C = C$

Affected flag(s)

TC2	TC1	TO	PD	OV	Z	AC	C
-	-	-	-	-	-	-	√

DEC [m] Decrement data memory
 Description Data in the specified data memory is decremented by one.

Operation $[m] \leftarrow [m] - 1$

Affected flag(s)

TC2	TC1	TO	PD	OV	Z	AC	C
-	-	-	-	-	√	-	-

DECA [m] Decrement data memory and place result in accumulator
 Description Data in the specified data memory is decremented by one, leaving the result in the accumulator. The contents of the data memory remain unchanged.
 Operation $ACC \leftarrow [m]-1$
 Affected flag(s)

TC2	TC1	TO	PD	OV	Z	AC	C
-	-	-	-	-	√	-	-

HALT Enter power down mode
 Description This instruction stops program execution and turns off the system clock. The contents of the RAM and registers are retained. The WDT and prescaler are cleared. The power down bit (PD) is set and the WDT time-out bit (TO) is cleared.
 Operation $PC \leftarrow PC+1$
 $PD \leftarrow 1$
 $TO \leftarrow 0$
 Affected flag(s)

TC2	TC1	TO	PD	OV	Z	AC	C
-	-	0	1	-	-	-	-

INC [m] Increment data memory
 Description Data in the specified data memory is incremented by one.
 Operation $[m] \leftarrow [m]+1$
 Affected flag(s)

TC2	TC1	TO	PD	OV	Z	AC	C
-	-	-	-	-	√	-	-

INCA [m] Increment data memory and place result in accumulator
 Description Data in the specified data memory is incremented by one, leaving the result in the accumulator. The contents of the data memory remain unchanged.
 Operation $ACC \leftarrow [m]+1$
 Affected flag(s)

TC2	TC1	TO	PD	OV	Z	AC	C
-	-	-	-	-	√	-	-

JMP addr Direct Jump
 Description Bits 0~11 of the program counter are replaced with the directly-specified address unconditionally, and control passed to this destination.
 Operation $PC \leftarrow \text{addr}$
 Affected flag(s)

TC2	TC1	TO	PD	OV	Z	AC	C
-	-	-	-	-	-	-	-

MOV A,[m] Move data memory to accumulator
 Description The contents of the specified data memory is copied to the accumulator.
 Operation $ACC \leftarrow [m]$
 Affected flag(s)

TC2	TC1	TO	PD	OV	Z	AC	C
-	-	-	-	-	-	-	-

MOV A,x Move immediate data to accumulator
 Description The 8-bit data specified by the code is loaded into the accumulator.
 Operation $ACC \leftarrow x$
 Affected flag(s)

TC2	TC1	TO	PD	OV	Z	AC	C
-	-	-	-	-	-	-	-

MOV [m],A Move accumulator to data memory
 Description The contents of the accumulator is copied to the specified data memory (one of the data memories).
 Operation $[m] \leftarrow ACC$
 Affected flag(s)

TC2	TC1	TO	PD	OV	Z	AC	C
-	-	-	-	-	-	-	-

NOP No operation
 Description No operation is performed. Execution continues with the next instruction.
 Operation $PC \leftarrow PC+1$
 Affected flag(s)

TC2	TC1	TO	PD	OV	Z	AC	C
-	-	-	-	-	-	-	-

OR A,[m] Logical OR accumulator with data memory
 Description Data in the accumulator and the specified data memory (one of the data memories) performs a bitwise logical_OR operation. The result is stored in the accumulator.

Operation $ACC \leftarrow ACC \text{ "OR" } [m]$

Affected flag(s)

TC2	TC1	TO	PD	OV	Z	AC	C
-	-	-	-	-	√	-	-

OR A,x Logical OR immediate data to accumulator

Description Data in the accumulator and the specified data performs a bitwise logical_OR operation. The result is stored in the accumulator.

Operation $ACC \leftarrow ACC \text{ "OR" } x$

Affected flag(s)

TC2	TC1	TO	PD	OV	Z	AC	C
-	-	-	-	-	√	-	-

ORM A,[m] Logical OR data memory with accumulator

Description Data in the data memory (one of the data memories) and the accumulator performs a bitwise logical_OR operation. The result is stored in the data memory.

Operation $[m] \leftarrow ACC \text{ "OR" } [m]$

Affected flag(s)

TC2	TC1	TO	PD	OV	Z	AC	C
-	-	-	-	-	√	-	-

RET Return from subroutine

Description The program counter is restored from the stack. This is a two-cycle instruction.

Operation $PC \leftarrow \text{Stack}$

Affected flag(s)

TC2	TC1	TO	PD	OV	Z	AC	C
-	-	-	-	-	-	-	-

RET A,x Return and place immediate data in accumulator
 Description The program counter is restored from the stack and the accumulator loaded with the specified 8-bit immediate data.
 Operation $PC \leftarrow \text{Stack}$
 $ACC \leftarrow x$

Affected flag(s)

TC2	TC1	TO	PD	OV	Z	AC	C
-	-	-	-	-	-	-	-

RETI Return from interrupt
 Description The program counter is restored from the stack, and interrupts enabled by setting the EMI bit. EMI is the enable master (global) interrupt bit (bit 0; register INTC).
 Operation $PC \leftarrow \text{Stack}$
 $EMI \leftarrow 1$

Affected flag(s)

TC2	TC1	TO	PD	OV	Z	AC	C
-	-	-	-	-	-	-	-

RL [m] Rotate data memory left
 Description The contents of the specified data memory is rotated left one bit with bit 7 rotated into bit 0.
 Operation $[m].(i+1) \leftarrow [m].i$; $[m].i$:bit i of the data memory (i=0-6)
 $[m].0 \leftarrow [m].7$

Affected flag(s)

TC2	TC1	TO	PD	OV	Z	AC	C
-	-	-	-	-	-	-	-

RLA [m] Rotate data memory left-place result in accumulator
 Description Data in the specified data memory is rotated left one bit with bit 7 rotated into bit 0, leaving the rotated result in the accumulator. The contents of the data memory remain unchanged.
 Operation $ACC.(i+1) \leftarrow [m].i$; $[m].i$:bit i of the data memory (i=0-6)
 $ACC.0 \leftarrow [m].7$

Affected flag(s)

TC2	TC1	TO	PD	OV	Z	AC	C
-	-	-	-	-	-	-	-

RLC [m] Rotate data memory left through carry
 Description The contents of the specified data memory and the carry flag are together rotated left one bit. Bit 7 replaces the carry bit; the original carry flag is rotated into the bit 0 position.
 Operation $[m].(i+1) \leftarrow [m].i$; $[m].i$:bit i of the data memory (i=0-6)
 $[m].0 \leftarrow C$
 $C \leftarrow [m].7$

Affected flag(s)

TC2	TC1	TO	PD	OV	Z	AC	C
-	-	-	-	-	-	-	√

RLCA [m] Rotate left through carry and place result in accumulator
 Description Data in the specified data memory and the carry flag are together rotated left one bit. Bit 7 replaces the carry bit and the original carry flag is rotated into bit 0 position. The rotated result is stored in the accumulator but the contents of the data memory remain unchanged.
 Operation $ACC.(i+1) \leftarrow [m].i$; $[m].i$:bit i of the data memory (i=0-6)
 $ACC.0 \leftarrow C$
 $C \leftarrow [m].7$

Affected flag(s)

TC2	TC1	TO	PD	OV	Z	AC	C
-	-	-	-	-	-	-	√

RR [m] Rotate data memory right
 Description The contents of the specified data memory are rotated right one bit with bit 0 rotated to bit 7.
 Operation $[m].i \leftarrow [m].(i+1)$; $[m].i$:bit i of the data memory (i=0-6)
 $[m].7 \leftarrow [m].0$

Affected flag(s)

TC2	TC1	TO	PD	OV	Z	AC	C
-	-	-	-	-	-	-	-

RRA [m] Rotate right and place result in accumulator
 Description Data in the specified data memory is rotated right one bit with bit 0 rotated into bit 7, leaving the rotated result in the accumulator. The contents of the data memory remain unchanged.

Operation $ACC.(i) \leftarrow [m].(i+1)$; $[m].i$:bit i of the data memory (i=0-6)
 $ACC.7 \leftarrow [m].0$

Affected flag(s)

TC2	TC1	TO	PD	OV	Z	AC	C
-	-	-	-	-	-	-	-

RRC [m] Rotate data memory right through carry
 Description The contents of the specified data memory and the carry flag are together rotated right one bit. Bit 0 replaces the carry bit; the original carry flag is rotated into the bit 7 position.

Operation $[m].i \leftarrow [m].(i+1)$; $[m].i$:bit i of the data memory (i=0-6)
 $[m].7 \leftarrow C$
 $C \leftarrow [m].0$

Affected flag(s)

TC2	TC1	TO	PD	OV	Z	AC	C
-	-	-	-	-	-	-	√

RRCA [m] Rotate right through carry and place result in accumulator
 Description Data of the specified data memory and the carry flag are together rotated right one bit. Bit 0 replaces the carry bit and the original carry flag is rotated into the bit 7 position. The rotated result is stored in the accumulator. The contents of the data memory remain unchanged.

Operation $ACC.i \leftarrow [m].(i+1)$; $[m].i$:bit i of the data memory (i=0-6)
 $ACC.7 \leftarrow C$
 $C \leftarrow [m].0$

Affected flag(s)

TC2	TC1	TO	PD	OV	Z	AC	C
-	-	-	-	-	-	-	√

SBC A,[m] Subtract data memory and carry from accumulator
 Description The contents of the specified data memory and the complement of the carry flag are together subtracted from the accumulator, leaving the result in the accumulator.

Operation $ACC \leftarrow ACC + \overline{[m]} + C$

Affected flag(s)

TC2	TC1	TO	PD	OV	Z	AC	C
-	-	-	-	√	√	√	√

SBCM A,[m] Subtract data memory and carry from accumulator
 Description The contents of the specified data memory and the complement of the carry flag are together subtracted from the accumulator, leaving the result in the data memory.

Operation $[m] \leftarrow ACC + \overline{[m]} + C$

Affected flag(s)

TC2	TC1	TO	PD	OV	Z	AC	C
-	-	-	-	√	√	√	√

SDZ [m] Skip if decrement data memory is zero
 Description The contents of the specified data memory are decremented by one. If the result is zero, the next instruction is skipped. If the result is zero, the following instruction, fetched during the current instruction execution, is discarded and a dummy cycle replaced to get the proper instruction (two cycles). Otherwise proceed with the next instruction (one cycle).

Operation Skip if $([m]-1)=0$, $[m] \leftarrow ([m]-1)$

Affected flag(s)

TC2	TC1	TO	PD	OV	Z	AC	C
-	-	-	-	-	-	-	-

SDZA [m] Decrement data memory-place result in ACC, skip if zero
 Description The contents of the specified data memory are decremented by one. If the result is zero, the next instruction is skipped. The result is stored in the accumulator but the data memory remains unchanged. If the result is zero, the following instruction, fetched during the current instruction execution, is discarded and a dummy cycle is replaced to get the proper instruction (two cycles). Otherwise proceed with the next instruction (one cycle).

Operation Skip if $([m]-1)=0$, $ACC \leftarrow ([m]-1)$

Affected flag(s)

TC2	TC1	TO	PD	OV	Z	AC	C
-	-	-	-	-	-	-	-

SET [m] Set data memory
 Description Each bit of the specified data memory is set to one.
 Operation $[m] \leftarrow FFH$
 Affected flag(s)

TC2	TC1	TO	PD	OV	Z	AC	C
-	-	-	-	-	-	-	-

SET [m].i Set bit of data memory
 Description Bit “i” of the specified data memory is set to one.
 Operation $[m].i \leftarrow 1$
 Affected flag(s)

TC2	TC1	TO	PD	OV	Z	AC	C
-	-	-	-	-	-	-	-

SIZ [m] Skip if increment data memory is zero
 Description The contents of the specified data memory is incremented by one. If the result is zero, the following instruction, fetched during the current instruction execution, is discarded and a dummy cycle is replaced to get the proper instruction (two cycles). Otherwise proceed with the next instruction (one cycle).
 Operation Skip if $([m]+1)=0$, $[m] \leftarrow ([m]+1)$
 Affected flag(s)

TC2	TC1	TO	PD	OV	Z	AC	C
-	-	-	-	-	-	-	-

SIZA [m] Increment data memory and place result in ACC, skip if zero
 Description The contents of the specified data memory is incremented by one. If the result is zero, the next instruction is skipped and the result stored in the accumulator. The data memory remains unchanged. If the result is zero, the following instruction, fetched during the current instruction execution, is discarded and a dummy cycle replaced to get the proper instruction (two cycles). Otherwise proceed with the next instruction (one cycle).
 Operation Skip if $([m]+1)=0$, $ACC \leftarrow ([m]+1)$
 Affected flag(s)

TC2	TC1	TO	PD	OV	Z	AC	C
-	-	-	-	-	-	-	-

SNZ [m].i Skip if bit “i” of the data memory is not zero
 Description If bit “i” of the specified data memory is not zero, the next instruction is skipped. If bit “i” of the data memory is not zero, the following instruction, fetched during the current instruction execution, is discarded and a dummy cycle is replaced to get the proper instruction (two cycles). Otherwise proceed with the next instruction (one cycle).

Operation Skip if [m].i≠0

Affected flag(s)

TC2	TC1	TO	PD	OV	Z	AC	C
-	-	-	-	-	-	-	-

SUB A,[m] Subtract data memory from accumulator
 Description The specified data memory is subtracted from the contents of the accumulator, leaving the result in the accumulator.

Operation $ACC \leftarrow ACC + \overline{[m]} + 1$

Affected flag(s)

TC2	TC1	TO	PD	OV	Z	AC	C
-	-	-	-	√	√	√	√

SUBM A,[m] Subtract data memory from accumulator
 Description The specified data memory is subtracted from the contents of the accumulator, leaving the result in the data memory.

Operation $[m] \leftarrow ACC + \overline{[m]} + 1$

Affected flag(s)

TC2	TC1	TO	PD	OV	Z	AC	C
-	-	-	-	√	√	√	√

SUB A,x Subtract immediate data from accumulator
 Description The immediate data specified by the code is subtracted from the contents of the accumulator, leaving the result in the accumulator.

Operation $ACC \leftarrow ACC + \overline{x} + 1$

Affected flag(s)

TC2	TC1	TO	PD	OV	Z	AC	C
-	-	-	-	√	√	√	√

SWAP [m] Swap nibbles within the data memory
 Description The low-order and high-order nibbles of the specified data memory (one of the data memory) are interchanged.
 Operation $[m].3 \sim [m].0 \leftrightarrow [m].7 \sim [m].4$
 Affected flag(s)

TC2	TC1	TO	PD	OV	Z	AC	C
-	-	-	-	-	-	-	-

SWAPA [m] Swap data memory and place result in accumulator
 Description The low-order and high-order nibbles of the specified data memory are interchanged, writing the result to the accumulator. The contents of the data memory remain unchanged.
 Operation $ACC.3 \sim ACC.0 \leftarrow [m].7 \sim [m].4$
 $ACC.7 \sim ACC.4 \leftarrow [m].3 \sim [m].0$
 Affected flag(s)

TC2	TC1	TO	PD	OV	Z	AC	C
-	-	-	-	-	-	-	-

SZ [m] Skip if data memory is zero
 Description If the contents of the specified data memory is zero, the following instruction, fetched during the current instruction execution, is discarded and a dummy cycle is replaced to get the proper instruction (two cycles). Otherwise proceed with the next instruction (one cycle).
 Operation Skip if $[m]=0$
 Affected flag(s)

TC2	TC1	TO	PD	OV	Z	AC	C
-	-	-	-	-	-	-	-

SZA [m] Move data memory to ACC, skip if zero
 Description The contents of the specified data memory is copied to accumulator. If the contents is zero, the following instruction, fetched during the current instruction execution, is discarded and a dummy cycle is replaced to get the proper instruction (two cycles). Otherwise proceed with the next instruction (one cycle).
 Operation Skip if $[m]=0$, $ACC \leftarrow [m]$
 Affected flag(s)

TC2	TC1	TO	PD	OV	Z	AC	C
-	-	-	-	-	-	-	-

SZ [m].i Skip if bit “i” of the data memory is zero

Description If bit “i” of the specified data memory is zero, the following instruction, fetched during the current instruction execution, is discarded and a dummy cycle is replaced to get the proper instruction (two cycles). Otherwise proceed with the next instruction (one cycle).

Operation Skip if [m].i=0

Affected flag(s)

TC2	TC1	TO	PD	OV	Z	AC	C
–	–	–	–	–	–	–	–

TABRDC [m] Move the ROM code (current page) to TBLH and data memory

Description The low byte of ROM code (current page) addressed by the table pointer (TBLP) is moved to the specified data memory and the high byte transferred to TBLH directly.

Operation [m] ← ROM code (low byte)
TBLH ← ROM code (high byte)

Affected flag(s)

TC2	TC1	TO	PD	OV	Z	AC	C
–	–	–	–	–	–	–	–

TABRDL [m] Move the ROM code (last page) to TBLH and data memory

Description The low byte of ROM code (last page) addressed by the table pointer (TBLP) is moved to the data memory and the high byte transferred to TBLH directly.

Operation [m] ← ROM code (low byte)
TBLH ← ROM code (high byte)

Affected flag(s)

TC2	TC1	TO	PD	OV	Z	AC	C
–	–	–	–	–	–	–	–

XOR A,[m] Logical XOR accumulator with data memory

Description Data in the accumulator and the indicated data memory performs a bitwise logical Exclusive_OR operation and the result is stored in the accumulator.

Operation ACC ← ACC “XOR” [m]

Affected flag(s)

TC2	TC1	TO	PD	OV	Z	AC	C
–	–	–	–	–	√	–	–

XORM A,[m]

Logical XOR data memory with accumulator

Description

Data in the indicated data memory and the accumulator perform a bitwise logical Exclusive_OR operation. The result is stored in the data memory. The zero flag is affected.

Operation

$[m] \leftarrow \text{ACC} \text{ "XOR" } [m]$

Affected flag(s)

TC2	TC1	TO	PD	OV	Z	AC	C
-	-	-	-	-	√	-	-

XOR A,x

Logical XOR immediate data to accumulator

Description

Data in the the accumulator and the specified data perform a bitwise logical Exclusive_OR operation. The result is stored in the accumulator. The zero flag is affected.

Operation

$\text{ACC} \leftarrow \text{ACC} \text{ "XOR" } x$

Affected flag(s)

TC2	TC1	TO	PD	OV	Z	AC	C
-	-	-	-	-	√	-	-