

Preliminary Information

October 6, 1999

This document contains information on a new product. The parametric information, although not fully characterized, is the result of testing initial devices.

Features

- 200 ps Part-to-Part Skew
- 50 ps Output-to-Output Skew
- Differential Design
- VBB Output
- Enable Input
- Voltage and Temperature Compensated Outputs
- Low Voltage V_{EE} Range of -3.0 to $-3.8V$
- $75K\Omega$ Internal Pulldown Resistors
- Fully Compatible with Motorola MC100LVE111
- Specified Over Industrial Temperature Range:
 $-40^{\circ}C$ to $85^{\circ}C$
- ESD Protection of $>2000V$
- Available in 28-pin PLCC Package

Low Voltage 1:9 Differential
ECL / PECL Clock Driver

28 Pin
PLCC Package

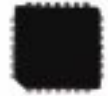

Description

The SK10/100LVE111E is a low skew 1-to-9 differential driver designed with clock distribution in mind. The SK10/100LVE111E's function and performance are similar to the SK100E111, with the added feature of low voltage operation. It accepts one signal input which can be either differential or single-ended if the VBB output is used. The signal is fanned out to 9 identical differential outputs. An enable input is also provided. A High disables the device by forcing all Q outputs Low and all Q* outputs High.

The device is specifically designed, modeled, and produced with low skew as the key goal. Optimal design and layout serve to minimize gate-to-gate skew within a device, and characterization is used to determine process control limits that ensure consistent tpd distributions from lot to lot. The net result is a dependable, guaranteed low skew device.

To ensure that the tight skew specification is met, it is necessary that both sides of the differential output are terminated into 50Ω , even if only one side is being used. In most applications, all nine differential pairs will be used and therefore terminated. In the case where fewer than nine pairs are used, it is necessary to terminate at least the output pairs on the same package side as the pair(s) being used on that side in order to maintain minimum skew. Failure to do this will result in small degradations of propagation delay (on the order of 10–20ps)

of the output(s) being used which, while not being catastrophic to most designs, will mean a loss of skew margin.

The SK10/100LVE111E, as with most other ECL devices, can be operated from a positive VCC supply in PECL mode. This allows the LVE111E to be used for high performance clock distribution in +3.3V systems. Designers can take advantage of the LVE111E's performance to distribute low skew clocks across the backplane or the board. In a PECL environment, series or Thevenin line terminations are typically used as they require no additional power supplies. For systems incorporating GTL, parallel termination offers the lowest power by taking advantage of the 1.2V supply as a terminating voltage.

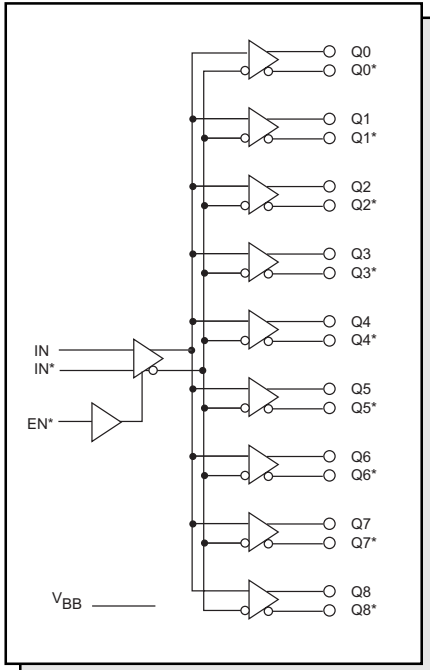

Pin	Function
IN, IN*	Differential Input Pair
EN*	Enable
Q0, Q0* – Q8, Q8*	Differential Outputs
VBB	VBB Output

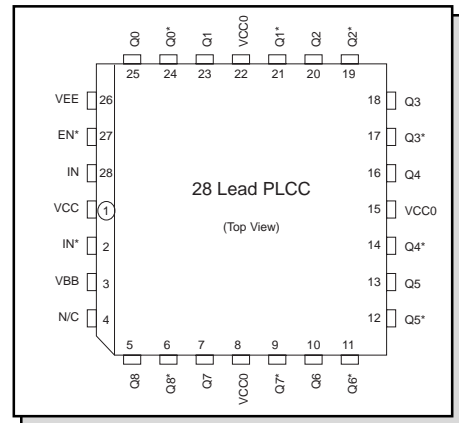

Absolute Maximum Ratings (Note 3)

Symbol	Parameter	Rating	Unit
V_{EE}	Power Supply ($V_{CC} = 0V$)	-4.5 to 0	V
V_I	Input Voltage ($V_{CC} = 0V$)	0 to -4.0	V
I_{OUT}	Output Current: Continuous Surge	50 100	mA mA
T_A	Operating Temperature Range	-40 to +85	°C
V_{EE} (note 4)	Operating Range	-3.8 to -3.0	V
T_{store}	Storage Temperature Range	-65 to +150	°C

SK10LVE111E ECL DC Electrical Characteristics
(V_{EE} = V_{EE} (min) to V_{EE} (max); V_{CC} = GND) (Notes 1 and 4)

Symbol	Characteristic	TA = -40°C			TA = 0°C			TA = +25°C			TA = +85°C			Unit
		Min	Typ	Max	Min	Typ	Max	Min	Typ	Max	Min	Typ	Max	
V _{OH}	Output HIGH Voltage	-1135		-890	-1080		-840	-1020		-810	-910		-720	mV
V _{OL}	Output LOW Voltage	-1950		-1650	-1950		-1630	-1950		-1630	-1950		-1595	mV
V _{IH}	Input HIGH Voltage	-1230		-890	-1170		-840	-1130		-810	-1060		-720	mV
V _{IL}	Input LOW Voltage	-1950		-1500	-1950		-1480	-1950		-1480	-1950		-1445	mV
V _{BB}	Output Reference Voltage	-1.43		-1.30	-1.38		-1.27	-1.35		-1.25	-1.31		-1.19	V
I _{IH}	Input HIGH Current			150			150			150			150	μA
I _{IL}	Input LOW Current	0.5			0.5			0.5			0.3			μA
I _{EE}	Power Supply Current	35		65	35		65	35		65	35		65	mA

SK10LVE111E PECL DC Electrical Characteristics
(V_{CC} = V_{CC} (min) to V_{CC} (max); V_{EE} = GND) (Notes 1 and 4)

Symbol	Characteristic	TA = -40°C			TA = 0°C			TA = +25°C			TA = +85°C			Unit
		Min	Typ	Max	Min	Typ	Max	Min	Typ	Max	Min	Typ	Max	
V _{OH}	Output HIGH Voltage ⁷	2165		3210	2220		2420	2280		2490	2390		2580	mV
V _{OL}	Output LOW Voltage ⁷	1350		1650	1350		1670	1350		1670	1350		1705	mV
V _{IH}	Input HIGH Voltage ⁷	2070		2410	2130		2460	2170		2410	2240		2580	mV
V _{IL}	Input LOW Voltage ⁷	1350		1800	1350		1820	1350		1820	1350		1855	mV
V _{BB}	Output Reference Voltage ⁷	1.87		2.00	1.92		2.03	1.95		2.05	1.99		2.11	V
I _{IH}	Input HIGH Current			150			150			150			150	μV
I _{IL}	Input LOW Current	0.5			0.5			0.5			0.3			μA
I _{EE}	Power Supply Current			66			66			66			66	mA

SK100LVE111E ECL DC Electrical Characteristics

 ($V_{EE} = V_{EE}(\text{min})$ to $V_{EE}(\text{max})$; $V_{CC} = \text{GND}$) (Notes 2 and 4)

Symbol	Characteristic	TA = -40°C			TA = 0°C			TA = +25°C			TA = +85°C			Unit
		Min	Typ	Max	Min	Typ	Max	Min	Typ	Max	Min	Typ	Max	
V _{OH}	Output HIGH Voltage	-1.14	-1.005	-0.880	-1.08	-0.955	-0.880	-1.08	-0.955	-0.880	-1.08	-0.955	-0.880	V
V _{OL}	Output LOW Voltage	-1.83	-1.695	-1.555	-1.810	-1.705	-1.620	-1.810	-1.705	-1.620	-1.810	-1.705	-1.620	V
V _{IH}	Input HIGH Voltage	-1.165		-0.880	-1.165		-0.880	-1.165		-0.880	-1.165		-0.880	V
V _{IL}	Input LOW Voltage	-1.810		-1.475	-1.810		-1.475	-1.810		-1.475	-1.810		-1.475	V
V _{BB}	Output Reference Voltage	-1.38		-1.26	-1.38		-1.26	-1.38		-1.26	-1.38		-1.26	V
V _{EE}	Power Supply Voltage	-3.0		-3.8	-3.0		-3.8	-3.0		-3.8	-3.0		-3.8	V
I _{IH}	Input HIGH Current			150			150			150			150	μA
I _{EE}	Power Supply Current		55	66		55	66		55	66		65	78	mA

SK100LVE111E PECL DC Electrical Characteristics

 ($V_{CC} = V_{CC}(\text{min})$ to $V_{CC}(\text{max})$; $V_{EE} = \text{GND}$) (Notes 2 and 4)

Symbol	Characteristic	TA = -40°C			TA = 0°C			TA = +25°C			TA = +85°C			Unit
		Min	Typ	Max	Min	Typ	Max	Min	Typ	Max	Min	Typ	Max	
V _{OH}	Output HIGH Voltage ⁷	2.16	2.295	2.420	2.22	2.345	2.420	2.22	2.345	2.420	2.22	2.345	2.420	V
V _{OL}	Output LOW Voltage ⁷	1.470	1.610	1.750	1.490	1.595	1.680	1.490	1.595	1.680	1.490	1.595	1.680	V
V _{IH}	Input HIGH Voltage ⁷	2.135		2.420	2.135		2.420	2.135		2.420	2.135		2.420	V
V _{IL}	Input LOW Voltage ⁷	1.490		1.825	1.490		1.825	1.490		1.825	1.490		1.825	V
V _{BB}	Output Reference Voltage ⁷	1.92		2.04	1.92		2.04	1.92		2.04	1.92		2.04	V
V _{CC}	Power Supply Voltage	3.0		3.8	3.0		3.8	3.0		3.8	3.0		3.8	V
I _{IH}	Input HIGH Current			150			150			150			150	μA
I _{EE}	Power Supply Current		55	66		55	66		55	66		65	78	mA

AC Characteristics

($V_{EE} = V_{EE}(\min)$ to $V_{EE}(\max)$; $V_{CC} = V_{CCO} = GND$) (Note 4)

Symbol	Characteristic	-40°C			0°C			25°C			85°C			Unit	Cond
		Min	Typ	Max	Min	Typ	Max	Min	Typ	Max	Min	Typ	Max		
t _{PLH} t _{PHL}	Propagation Delay to Output IN (Differential) IN (Single-Ended)	400 350		650 700	435 385		625 675	440 390		630 680	445 395		635 685	ps	8. 9.
t _{skew}	Within-Device Skew Part-to-Part Skew (Diff)			50 250			50 250			50 250			50 250	ps	10.
V _{PP}	Minimum Input Swing	500			500			500			500			mV	11.
V _{CMR}	Common Mode Range	-1.5		-0.4	-1.5		-0.4	-1.5		-0.4	-1.5		-0.4	V	12.
t _r , t _f	Rise/Fall Time 20% to 80%	200		600	200		600	200		600	200		600	ps	20%-80%

Notes:

- 10LVE111E circuits are designed to meet the DC specifications shown in the table after thermal equilibrium has been established.
The circuit is in a test socket or mounted on a printed circuit board and transverse airflow greater than 500 lfm is maintained. Outputs are terminated through a 50Ω resistor to -2.0V.
- The same DC parameter values apply across the full V_{EE} range of -3.0 to -3.8V. Outputs are terminated through a 50Ω resistor to -2.0V. 100LVE111E circuits are designed to meet the DC specifications shown in the table where transverse airflow greater than 500 lfm is maintained.
- Absolute maximum rating, beyond which device life may be impaired unless otherwise specified on an individual data sheet.
- Parametric values specified at:
10LVE111E Series: -3.0 to -3.8V
100 LVE111E Series: -3.0 to -3.8V; PECL Power Supply: +3.0V to +3.8V
- Guaranteed HIGH signal for all inputs.
- Guaranteed LOW signal for all inputs.
- These values are for V_{CC} = 3.3V. Level Specifications will vary 1:1 with V_{CC}.
- The differential propagation delay is defined as the delay from the crossing points of the differential input signals to the crossing point of the differential output signals.
- The single-ended propagation delay is defined as the delay from the 50% point of the input signal to the 50% point of the output signal.
- The within-device skew is defined as the worst case difference between any two similar delay paths within a single device.
- V_{PP(min)} is defined as the minimum input differential voltage which will cause no increase in the propagation delay. The V_{PP(min)} is AC limited for the E111 as a differential input as low as 50 mV will still produce full ECL levels at the output.
- V_{CMR} is defined as the range within which the V_{IH} level may vary, with the device still meeting the propagation delay specification. The V_{IL} level must be such that the peak-to-peak voltage is less than 1.0V and greater than or equal to V_{PP(min)}.

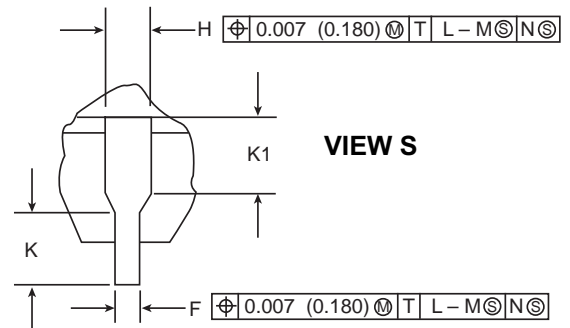
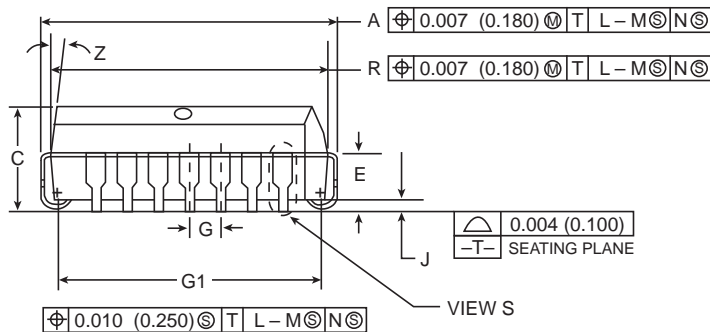
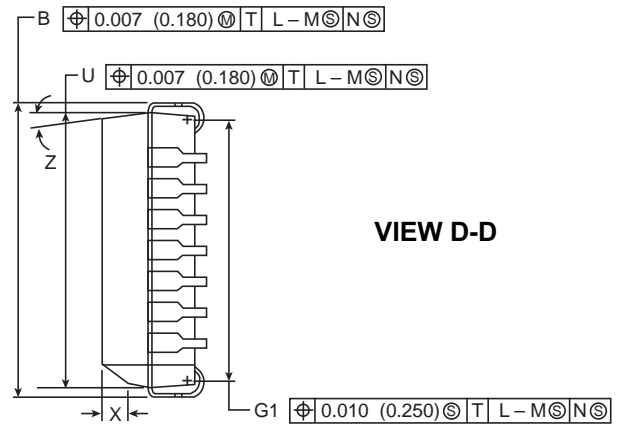
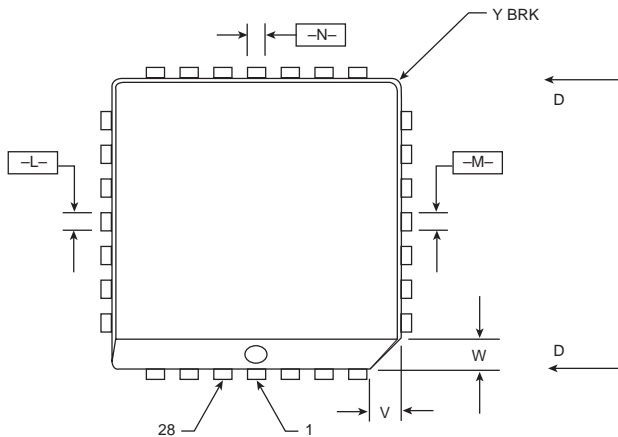
Package Information

NOTES:

- Datums -L-, -M-, and -N- determined where top of lead shoulder exits plastic body at mold parting line.
- DIM G1, true position to be measured at Datum -T-, Seating Plane.
- DIM R and U do not include mold flash. Allowable mold flash is 0.010 (0.250) per side.
- Dimensioning and tolerancing per ANSI Y14.5M, 1982.
- Controlling Dimension: Inch.
- The package top may be smaller than the package bottom by up to 0.012 (0.300). Dimensions R and U are determined at the outermost extremes of the plastic body exclusive of mold flash, tie bar burrs, gate burrs and interlead flash, but including any mismatch between the top and bottom of the plastic body.
- Dimension H does not include Dambar protrusion or intrusion. The Dambar protrusion(s) shall not cause the H dimension to be greater than 0.037 (0.940). The Dambar intrusion(s) shall not cause the H dimension to be smaller than 0.025 (0.635).

DIM	INCHES		MILLIMETERS	
	MIN	MAX	MIN	MAX
A	0.485	0.495	12.32	12.57
B	0.485	0.495	12.32	12.57
C	0.165	0.180	4.20	4.57
E	0.090	0.110	2.29	2.79
F	0.013	0.019	0.33	0.48
G	0.050	BSC	1.27	BSC
H	0.026	0.032	0.66	0.81
J	0.020	--	0.51	--
K	0.025	--	0.64	--
R	0.450	0.456	11.43	11.58
U	0.450	0.456	11.43	11.58
V	0.042	0.048	1.07	1.21
W	0.042	0.048	1.07	1.21
X	0.042	0.056	1.07	1.42
Y	--	0.020	--	0.50
Z	2°	10°	2°	10°
G1	0.410	0.430	10.42	10.92
K1	0.040	--	1.02	--