

Three Phase Rectifier Bridge

in ECO-PAC 2

$I_{dAV} = 117 \text{ A}$
 $V_{RRM} = 800-1600 \text{ V}$

Preliminary data

V_{RSM} V	V_{RRM} V	Types
900	800	VUO 122-08NO7
1300	1200	VUO 122-12NO7
1500	1400	VUO 122-14NO7
1700	1600	VUO 122-16NO7

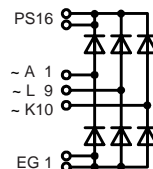

Pin arrangement see outlines

Symbol	Test Conditions	Maximum Ratings
I_{dAV} ①	$T_C = 100^\circ\text{C}$, module	117 A
I_{FSM}	$T_{VJ} = 45^\circ\text{C}$; $V_R = 0$	t = 10 ms (50 Hz), sine 900 A
		t = 8.3 ms (60 Hz), sine 990 A
I^2t	$T_{VJ} = T_{VJM}$; $V_R = 0$	t = 10 ms (50 Hz), sine 770 A
		t = 8.3 ms (60 Hz), sine 850 A
T_{VJ}	$T_{VJ} = 45^\circ\text{C}$; $V_R = 0$	t = 10 ms (50 Hz), sine 4050 A ² s
		t = 8.3 ms (60 Hz), sine 4050 A ² s
T_{VJM}	$T_{VJ} = T_{VJM}$; $V_R = 0$	t = 10 ms (50 Hz), sine 2950 A ² s
		t = 8.3 ms (60 Hz), sine 2950 A ² s
T_{stg}		-40...+150 °C
V_{ISOL}	50/60 Hz, RMS $I_{ISOL} \leq 1 \text{ mA}$	t = 1 min 2500 V~
		t = 1 s 3000 V~
M_d	Mounting torque (M4)	1.5 - 2 Nm
		14 - 18 lb.in.
Weight	typ.	18 g

Features

- Package with DCB ceramic base plate
- Isolation voltage 3000 V~
- Planar passivated chips
- Low forward voltage drop
- Leads suitable for PC board soldering

Applications

- Supplies for DC power equipment
- Input rectifiers for PWM inverter
- Battery DC power supplies
- Field supply for DC motors

Advantages

- Easy to mount with two screws
- Space and weight savings
- Improved temperature and power cycling capability
- Small and light weight

Dimensions in mm (1 mm = 0.0394")

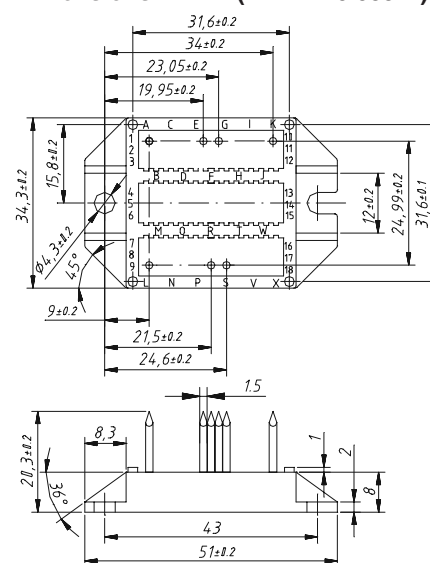

Symbol	Test Conditions	Characteristic Values
I_R	$V_R = V_{RRM}$; $T_{VJ} = 25^\circ\text{C}$	$\leq 0.5 \text{ mA}$
	$V_R = V_{RRM}$; $T_{VJ} = T_{VJM}$	$\leq 5 \text{ mA}$
V_F	$I_F = 200 \text{ A}$; $T_{VJ} = 25^\circ\text{C}$	$\leq 1.75 \text{ V}$
V_{T0}	For power-loss calculations only	0.8 V
r_T		4 mΩ
R_{thJC}	per diode; DC current	0.85 K/W
	per module	0.142 K/W
R_{thJH}	per diode, DC current (typ.)	1.15 K/W
	per module (typ.)	0.192 K/W
d_s	Creeping distance on surface	11.2 mm
d_A	Creepage distance in air	9.7 mm
a	Max. allowable acceleration	50 m/s ²

Data according to IEC 60747 refer to a single diode unless otherwise stated
 ① for resistive load at bridge output.

IXYS reserves the right to change limits, test conditions and dimensions.