

### DUAL COMPARATOR

- Be Possible to Operate at the Wide Range Single or Two Supply Voltage.
- Low Supply Current :  $I_{CC}=0.8mA(Typ.)$ .
- Low Input Offset Voltage :  $V_{IO}=2mV(Typ.)$ .
- Wide Common Mode Input Voltage :  $0V_{DC}$  to  $V_{CC}-1.5V_{DC}$ .
- Output is Compatible with TTL, DTL, MOS and C-MOS.
- Output is Open Collector and Wired-OR Possible.
- Possible to exchange the position of Pin⑨ for Pin① because of Pin connection being symmetric (KIA393S only).
- The Pin① and Pin⑨ of Lead frame was each other connected (KIA393S Only).

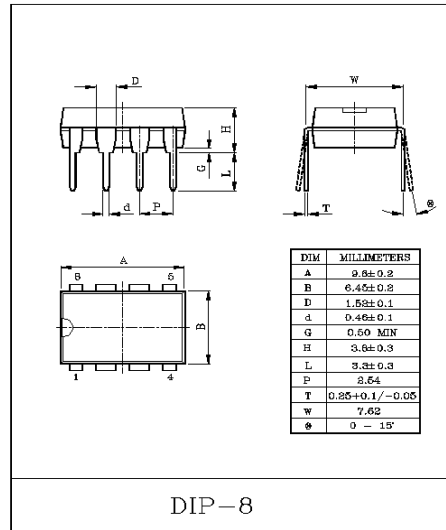

DIP-8

### PIN CONNECTION (TOP VIEW)

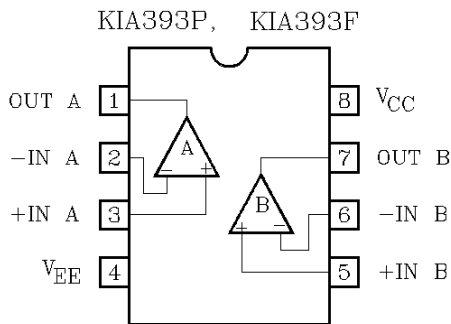

### KIA393S

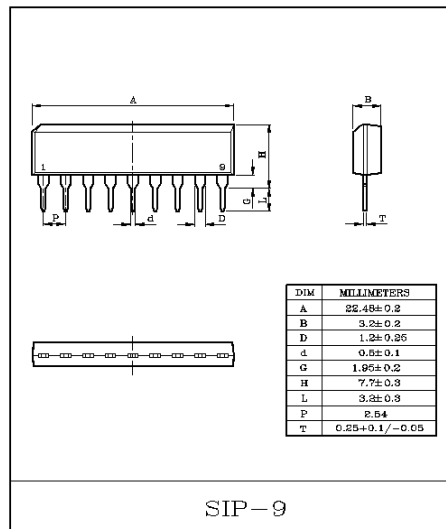
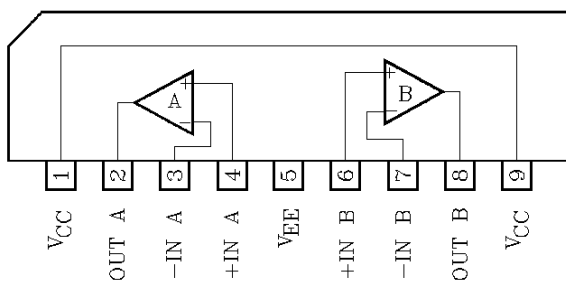

SIP-9

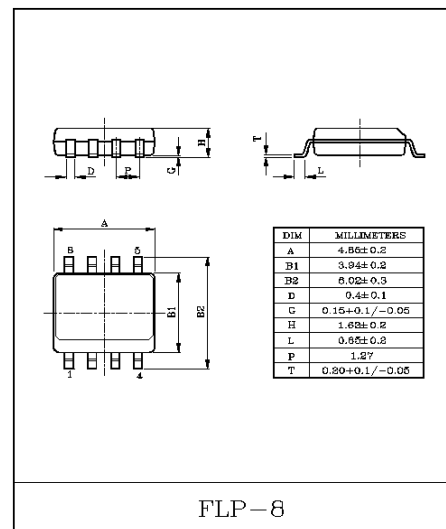

FLP-8

# KIA393P/S/F

## MAXIMUM RATINGS (Ta=25°C)

CHARACTERISTIC		SYMBOL	RATING	UNIT
Supply Voltage		V <sub>CC</sub>	±18, 36	V
Differential Input Voltage		DV <sub>IN</sub>	±18, 36	V
Common Mode Input Voltage		CMV <sub>IN</sub>	-0.3~V <sub>CC</sub>	V
Power Dissipation	KIA393P KIA393S	P <sub>D</sub>	500	mW
	KIA393F		240	
	Operating Temperature		T <sub>opr</sub>	
Storage Temperature		T <sub>stg</sub>	-55~125	°C
Pin① to Pin⑨ Maximum Current	KIA393S	I <sub>MAX</sub>	1	A

## ELECTRICAL CHARACTERISTICS (V<sub>CC</sub>=5V, V<sub>EE</sub>=GND, Ta=25°C)

CHARACTERISTIC	SYMBOL	TEST CONDITION	MIN.	TYP.	MAX.	UNIT
Input Offset Voltage	V <sub>IO</sub>	V <sub>O</sub> =1.4V	-	2	5	mV
Input Offset Current	I <sub>IO</sub>	-	-	5	50	nA
Input Bias Current	I <sub>I</sub>	-	-	25	250	nA
Common Mode Input Voltage	CMV <sub>IN</sub>	-	0	V <sub>CC</sub> -1.5	-	V
Voltage Gain	G <sub>V</sub>	R <sub>L</sub> =15kΩ	-	200	-	V/mV
Supply Current	I <sub>CC</sub>	No load	-	0.8	2	mA
Sink Current	I <sub>sink</sub>	+IN=0V, -IN=1V, V <sub>OL</sub> =1.5V	6	16	-	mA
Output Voltage ("L" Level)	V <sub>OL</sub>	+IN=0V, -IN=1V, I <sub>sink</sub> =3mA	-	0.2	0.4	V
Output Leak Current	I <sub>LEAK</sub>	+IN=1V, -IN=0V, V <sub>O</sub> =5V	-	0.1	-	nA
Response Time	t <sub>rsp</sub>	R <sub>L</sub> =5.1kΩ, C <sub>L</sub> =15pF	-	1.3	-	μS

## EQUIVALENT CIRCUIT

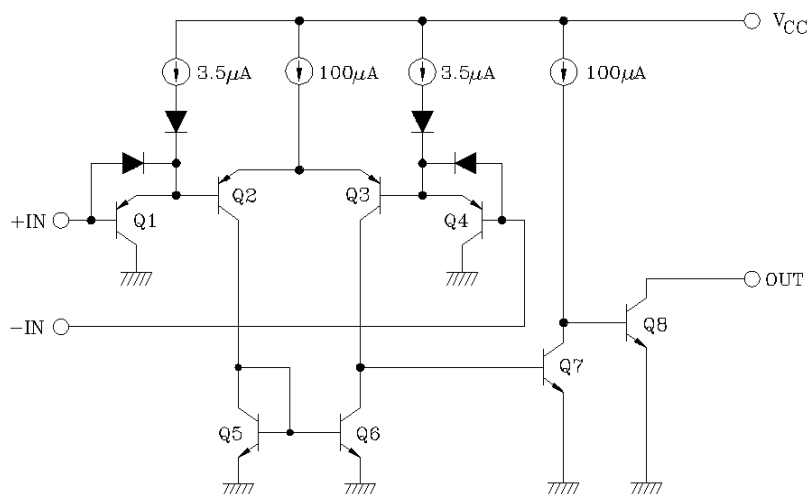

# KIA393P/S/F

